

**MOTORI IN CARCASSA TUBO / SMOOTH BODY MOTORS**

 **NERIMOTORI**  
Experience the power





Studiati per resistere alla corrosione e all'ossidazione. Resistenti all'acqua, all'umidità e agli agenti chimici.

Motore elettrico trifase IEC 56



Motori elettrici trifase resistenti all'acqua ed all'umidità. Progettati per essere impiegati in ambienti ostili a contatto diretto con sostanze chimiche presenti nei detersivi. La carcassa ed i componenti esterni sono in alluminio anodizzato, che ha un'elevata resistenza alla corrosione.

*Designed to be resistant to corrosion and oxidation. Resistant to water, humidity and chemical agents.*

*IEC 56 three-phase electric motor*



*Three-phase electric motors water and humidity resistant. Designed to be used in extreme conditions in direct contact with the chemical components of detergents. Both the enclosure and the external components are made by anodised aluminium, which is highly resistant against the corrosion.*



L'elevato grado di protezione è garantito da un accoppiamento flangia/scudo per interferenza con la carcassa.  
Grado di protezione IP66.

*The high degree of protection is guaranteed by the interference of the flange/shield coupling with the body.  
IP66 Degree of protection.*



### Esecuzioni speciali a richiesta

- Albero in acciaio AISI 416/420
- Esecuzioni meccaniche speciali
- Alimentazione monofase a richiesta

### Customized options

- AISI 416/420 steel shaft
- Customized mechanical solution
- Single-phase power supply on request





Studiati per resistere alla corrosione e all'ossidazione. Resistenti all'acqua, all'umidità e agli agenti chimici.

Motore elettrico trifase IEC 63-71-80.  
*IEC 63-71-80 three-phase electric motor.*

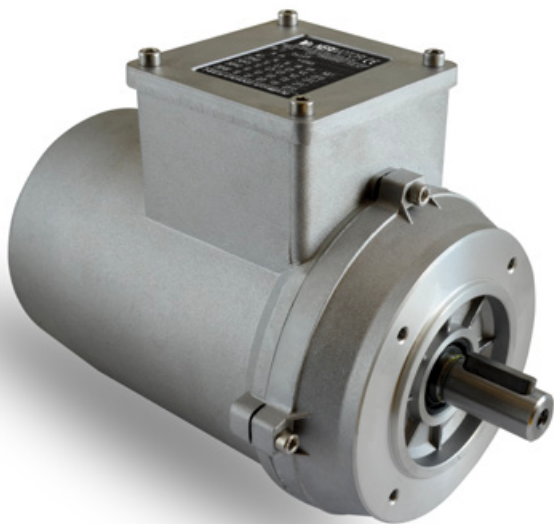

Motori elettrici trifase resistenti all'acqua ed all'umidità. Progettati per essere impiegati in ambienti ostili a contatto diretto con sostanze chimiche presenti nei detersivi. La carcassa ed i componenti esterni sono pressofusi in lega di alluminio EN44300 che ha un'elevata resistenza alla corrosione.

*Designed to be resistant to corrosion and oxidation. Resistant to water, humidity and chemical agents.*

Motore elettrico trifase **autofrenante** IEC 63-71-80.  
*IEC 63-71-80 **self-braking** three-phase electric motor.*

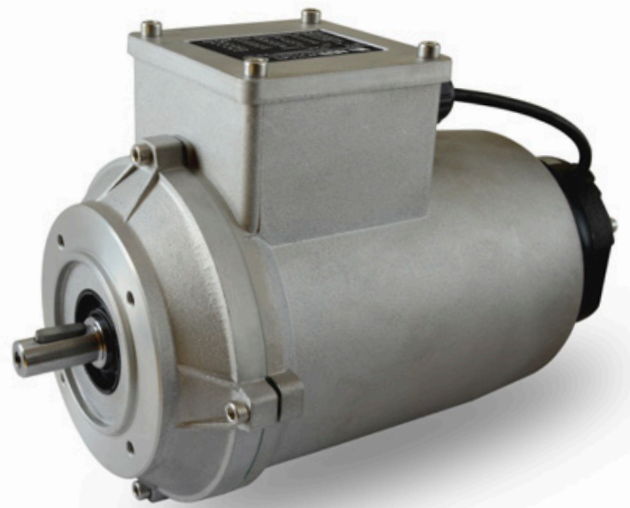

*Three-phase electric motors water and humidity resistant. Designed to be used in extreme conditions in direct contact with the chemical components of detergents. Both the enclosure and the external components are made by die cast aluminium league EN44300 which is highly resistant against the corrosion.*



L'elevato grado di protezione è garantito da una resina epossidica bicomponente che viene colata all'interno del vano morsettiera proteggendo l'avvolgimento da eventuali infiltrazioni.

*The high protection degree is provided by a bi-component epoxy resin that is poured into the terminal box to protect windings from any infiltrations.*

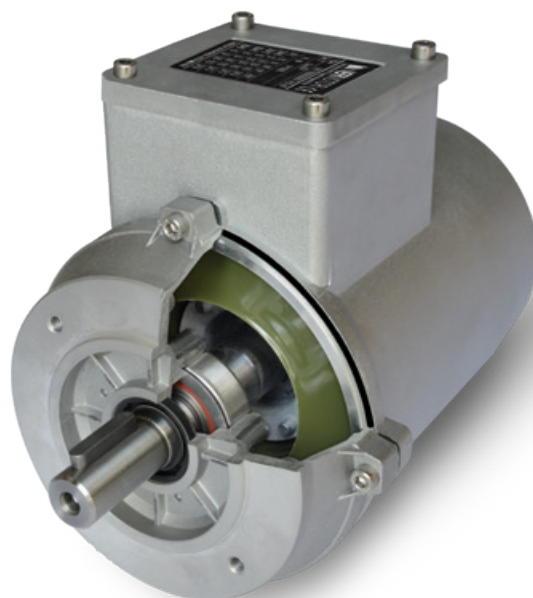
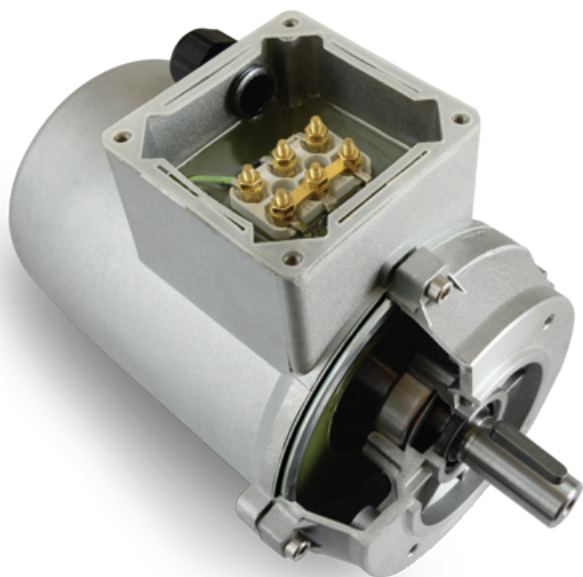

### Esecuzioni speciali a richiesta

- Leva di sblocco
- Albero in acciaio AISI 416/420
- Sistema di isolamento UL/CSA
- Incapsulamento dell'avvolgimento
- Esecuzioni meccaniche speciali

### Customized options

- Hand release
- AISI 416/420 steel shaft
- Insulation system UL/CSA
- Winding encapsulation
- Customized mechanical solution



Il design liscio e compatto  
è il suo valore aggiunto

*The smooth and compact  
design is its added value*

Alcuni settori di applicazione:

*Some areas of application:*

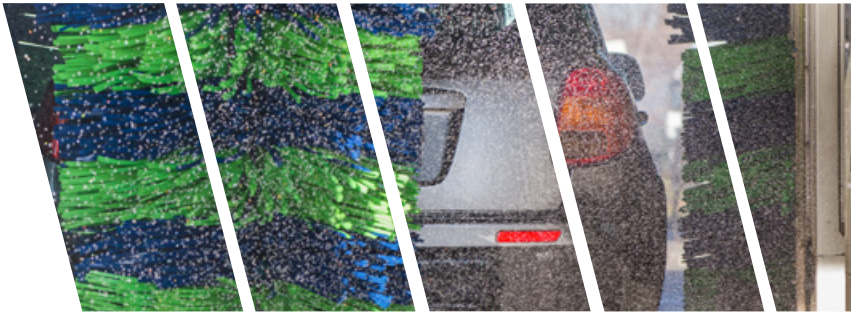

Impianti di autolavaggio  
*Car wash systems*



Pulizia stradale  
*Road cleaning*



Industria alimentare  
*Food industry*



Industrie ceramiche  
*Ceramic industry*



Montascale  
*Lift*

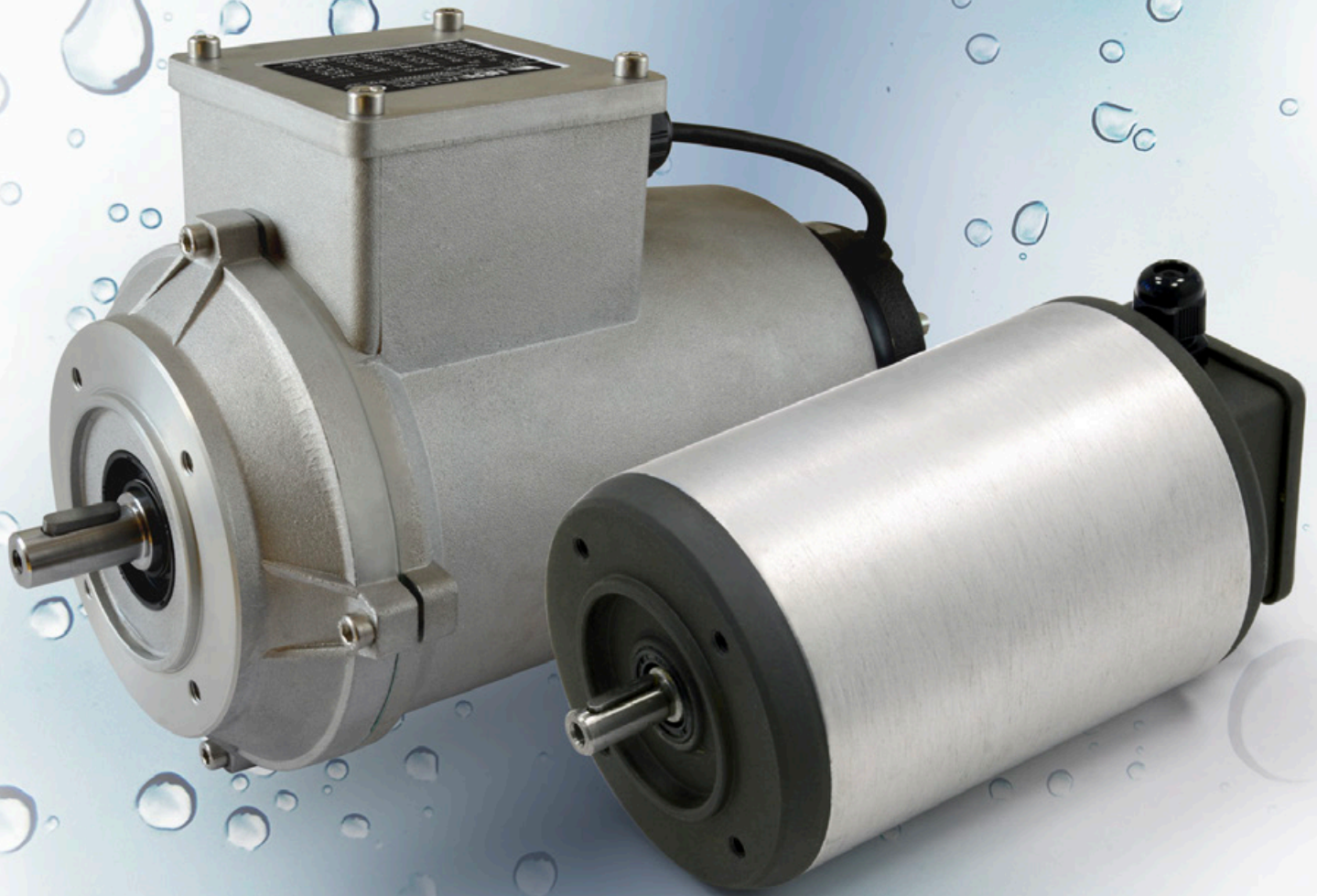

Motore elettrico trifase IEC 56  
 Forma costruttiva B14

 IEC 56 three-phase electric motor  
 B14 frame

## 4 POLI / POLES 1500 rpm - V 230 - 400/50 Hz

TIPO TYPE	Potenza Power		rpm	In400V A	Eff.%	CosF	Ia/In	Ca/Cn	Servizio Duty
	kW	hp							
T56C	0,06	0,08	1400	0,38	46	0,5	2,7	3,3	S1
T56C	0,09	0,12	1350	0,4	54,2	0,6	2,8	2,5	S3 50%
T56C	0,11	0,15	1300	0,44	53	0,7	2,5	1,7	S3 30%

## CARATTERISTICHE TECNICHE - TECHNICAL FEATURES

<b>Poli / Poles</b>	4 (2 e 6 Poli a richiesta / 2 and 6 poles on request)
<b>Forma costruttiva / Type of construction</b>	B14
<b>Materiale / Material</b>	Alluminio anodizzato - Anodized aluminium
<b>Classe di isolamento / Insulation class</b>	F (Classe H su richiesta - Class H on request)
<b>Ventilazione / Ventilation</b>	IC410 TENV
<b>Grado di protezione / Protection class</b>	Motore IP66 / Motor IP66
<b>Tensioni e frequenze / Tensions and frequencies</b>	Speciali a richiesta Special on request
<b>Accessori opzionali / Optional accessories</b>	Protezioni termiche, scaldiglie anticondensa Thermal overload cut-out switches, anti-condensation heaters
<b>Certificazione / Certification</b>	CE
<b>Su richiesta / On request</b>	GOST-R

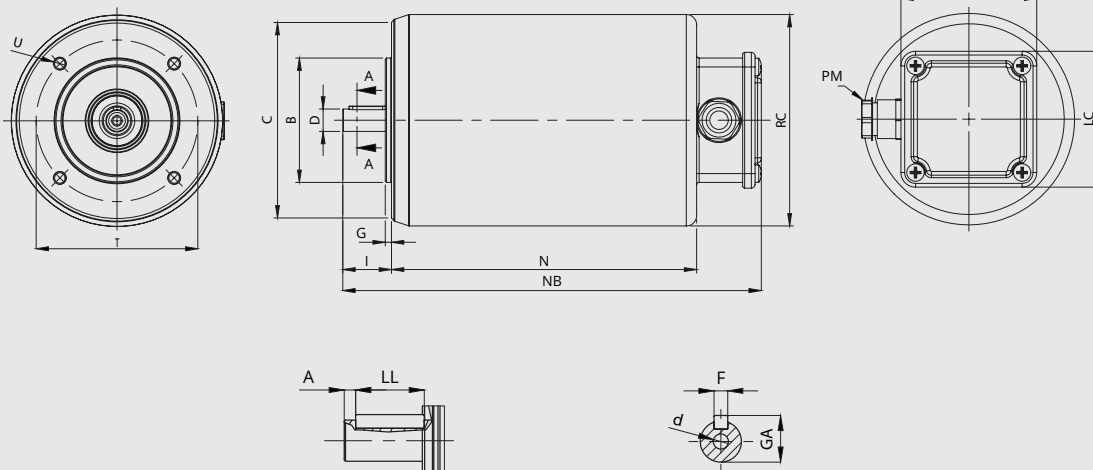

Dimensioni Dimensions	GR / Size 56 mm
<b>D</b>	9
<b>B</b>	50
<b>C</b>	79
<b>RC</b>	85
<b>LC</b>	55
<b>NB</b>	169
<b>I</b>	20
<b>G</b>	2,5
<b>N</b>	123
<b>T</b>	65
<b>U</b>	N°4 M5
<b>PM</b>	PG 7
<b>A</b>	2,5
<b>LL</b>	15
<b>F</b>	3
<b>GA</b>	10,2
<b>d</b>	M4x13



## Motore elettrico trifase IEC 63-71-80

Forma costruttiva B14 \*

## IEC 63-71-80 three-phase electric motor

B14 frame\*

### 4 POLI / POLES 1500 rpm - V 230 - 400/50 Hz

TIPO TYPE	Potenza Power		rpm	In 400V A	Eff.%	CosF	Ia/In	Ca/Cn	Servizio Duty
	kW	hp							
T63B	0,18	0,25	1340	0,7	53,1	0,7	2,8	2,2	S3 30%
T63C	0,25	0,35	1300	0,8	60,2	0,75	2,8	1,9	S3 30%
T63D	0,37	0,50	1340	1,3	61,2	0,67	2,8	2,1	S3 30%
T63D	0,13	0,18	1380	0,6	51	0,7	2	2,2	S1
T71C	0,25	0,35	1425	0,8	70	0,7	5,5	3,4	S1
T71C	0,37	0,50	1435	1,3	70	0,6	4,9	3,8	S3 60%
T80A4	0,25	0,35	1445	1,10	66	0,5	4,8	4,2	S3 60%
T80A4	0,25	0,35	1440	1,10	66	0,5	4,3	3,2	S1
T80A4	0,37	0,50	1420	1,20	71,3	0,6	4,0	2,7	S3 60%
T80B4	0,37	0,50	1430	1,25	74	0,6	4,1	1,9	S1
T80B4	0,55	0,75	1420	1,90	69,4	0,6	4,2	2,3	S3 60%
T80C4	0,75	1,00	1410	2,10	75	0,7	4,0	1,9	S3 60%
T80D4	0,55	0,75	1425	1,55	78	0,7	5,6	3,2	S1
T80D4	1,10	1,50	1380	2,80	75,5	0,7	3,6	1,8	S3 30%

### CARATTERISTICHE TECNICHE - TECHNICAL FEATURES

<b>Poli / Poles</b>	4 (2 e 6 Poli a richiesta / 2 and 6 poles on request)
<b>Forma costruttiva / Type of construction</b>	B14*
<b>Materiale / Material</b>	Alluminio EN44300 - Aluminium EN44300
<b>Classe di isolamento / Insulation class</b>	F (Classe H a richiesta - Class H on request)
<b>Ventilazione / Ventilation</b>	IC410 TENV
<b>Tipo di freno (a richiesta) / Brake type (on request)</b>	Freno in CC - DC brake (4Nm / 6Nm / 8Nm)
<b>Grado di protezione / Protection class</b>	Motore IP56 (IP66 e IP67 a richiesta) Motor IP56 (IP66 and IP67 on request) Freno IP65 (IP66 a richiesta) / Brake IP65 (IP66 on request)
<b>Viteria / Screws</b>	Inox A4 Standard Inox A4 Standard
<b>Tensioni e frequenze / Tensions and frequencies</b>	Speciali a richiesta Special on request
<b>Accessori opzionali / Optional accessories</b>	Encoder, protezioni termiche, scaldiglie anticondensa, leva di sblocco, alimentazione freno separata, incapsulamento dell'avvolgimento Encoder, thermal protection, cut-out switches, anti-condensation heaters, hand release lever, separate brake power supply, winding encapsulation
<b>Certificazione / Certification</b>	CE
<b>Su richiesta / On request</b>	UL, CSA, GOST-R

\* A richiesta B5 / B5 on request.

Motore elettrico trifase IEC 63

Forma costruttiva B14

IEC 63 three-phase electric motor

B14 frame

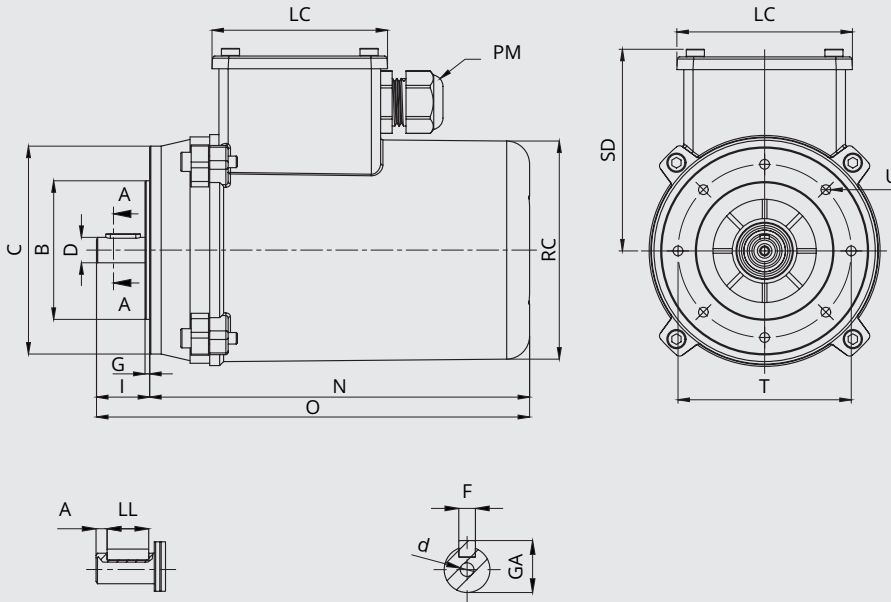

Dimensioni Dimensions	GR / Size 63 mm
D	11
B	60
C	90
RC	95
LC	76
SD	88
I	23
G	2
N	165
O	188
T	75
U	N°8 M5
PM	PM 20
A	4
LL	15
F	4
GA	12,5
d	M4x18

Motore elettrico trifase autofrenante  
IEC 63

Forma costruttiva B14

IEC 63 self-braking three-phase electric  
motor

B14 frame

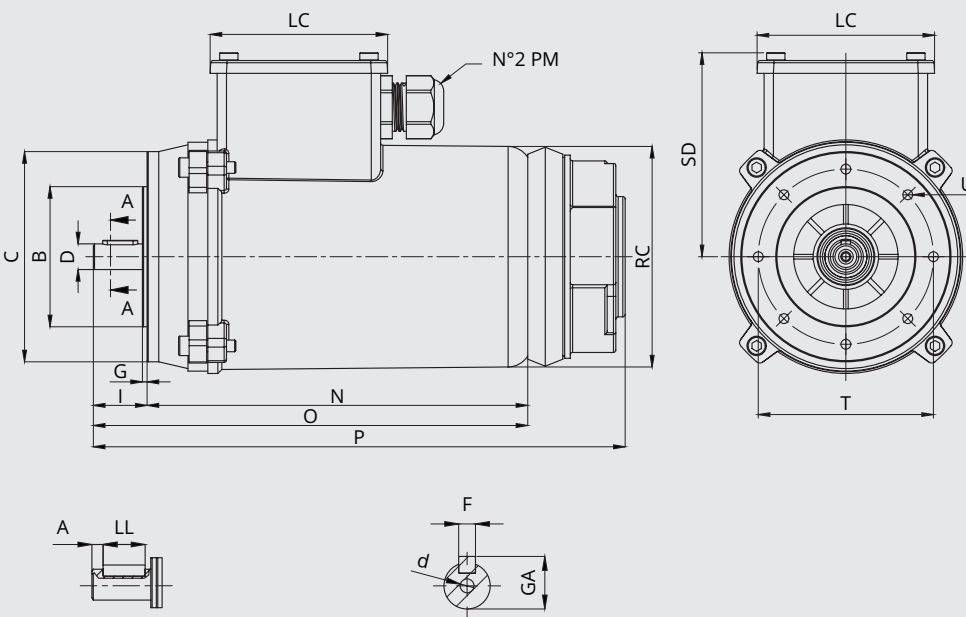

Dimensioni Dimensions	GR 63 con freno Size 63 with brake mm
D	11
B	60
C	90
RC	95
LC	76
SD	88
I	23
G	2
N	163
O	186
T	75
P	228
U	N°8 M5
PM	N°2 PM 20
A	4
LL	15
F	4
GA	12,5
d	M4x18



## Motore elettrico trifase IEC 71-80

Forma costruttiva B14 \*

## IEC 71-80 three-phase electric motor

B14 frame\*

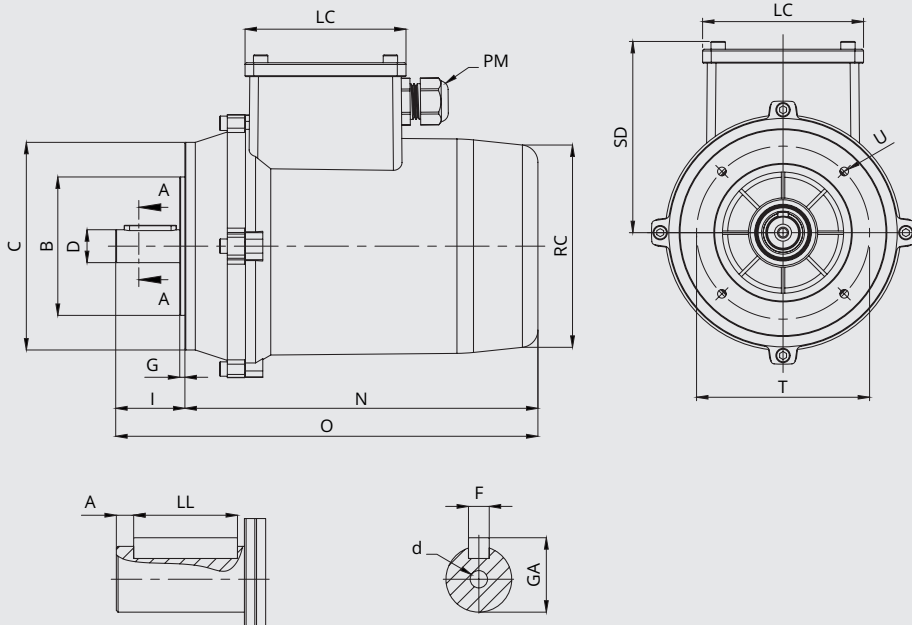

Dimensioni Dimensions	GR / Size 71 mm	GR / Size 80 mm
D	14	19
B	70	80
C	105	120
RC	117	117
LC	76	93
SD	106	111
I	30	40
G	3	3
N	168	204
O	198	244
T	85	100
U	N°4 M6	N°4 M6
PM	PM 16	PM 20
A	5	5
LL	20	30
F	5	6
GA	16	21,5
d	M5x18	M6x18

\* A richiesta B5 / B5 on request.

N.B: Ogni motore Tube monta PGM, a richiesta su 4 lati della bassetta.

N.B: Each Tube motor is equipped with PGM, on request on 4 sides of the bases.

## Motore elettrico trifase autofrenante IEC 71-80

Forma costruttiva B14 \*

## IEC 71-80 self-braking three-phase electric motor

B14 frame\*

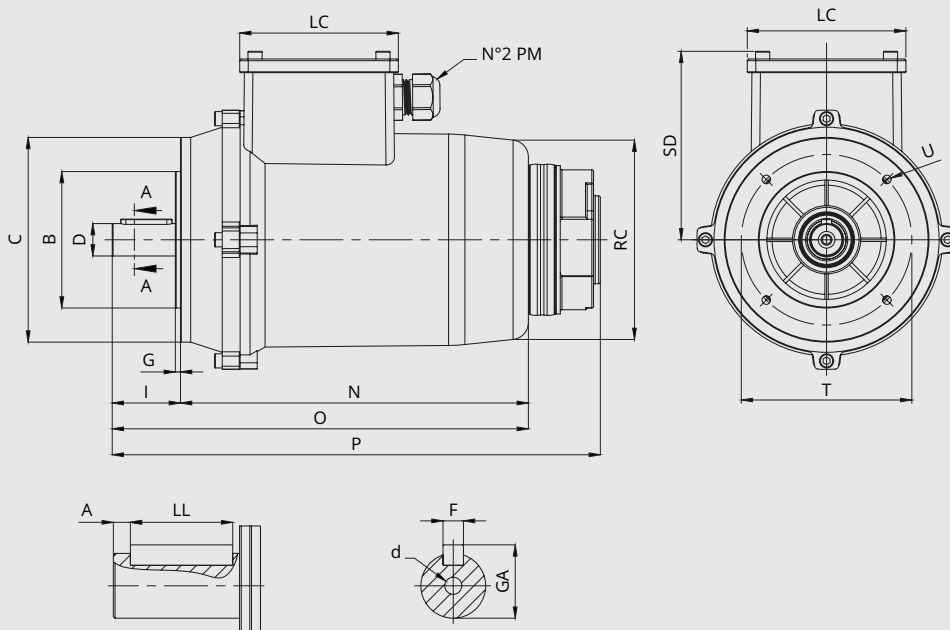

Dimensioni Dimensions	GR 71 con freno Size 71 with brake mm	GR 80 con freno Size 80 with brake mm
D	14	19
B	70	80
C	105	120
RC	117	117
LC	76	93
SD	106	111
I	30	40
G	3	3
N	168	204
O	198	244
T	85	100
P	210	287
U	N°4 M6	N°4 M6
PM	N°2 PM 16	N°2 PM 20
A	5	5
LL	20	30
F	5	6
GA	16	21,5
d	M5x18	M6x18

\* A richiesta B5 / B5 on request.

N.B: Ogni motore Tube monta PGM, a richiesta su 4 lati della bassetta, se freno maggiorato contattare UT.

N.B: Each Tube motor is equipped with PGM, on request on 4 sides of the bases, if increased brake contact UT.



Made in Italy EU

