

Product range



LOW VOLTAGE GENERAL PURPOSE 3-PHASE INDUCTION MOTORS	<p>Three-phase motors with squirrel-cage rotor series (2)Sg(m), Sh.</p> <p>High efficiency motors series 2SIE, 3SIE and 4SIE (efficiency classes IE2, IE3, IE4)</p>	<p>from 0,04kW up to 2200kW</p>	<p>for general purpose applications like pumps, fans, compressors; complying with the newest efficiency requirements</p>
GENERAL PURPOSE 1-PHASE INDUCTION MOTORS	<p>Single-phase motors with squirrel-cage rotor series SEh(R), SEMh(R).</p> <ul style="list-style-type: none"> – motors with standard starting torque – motors with increased starting torque – motors with high starting torque. 	<p>from 0,04kW up to 2,2kW</p>	<p>for general purpose applications like pumps, fans, compressors, woodworking machines, devices for food processing, concrete mixers etc.</p>
HIGH VOLTAGE INDUCTION MOTORS UP TO 11kV	<p>Three-phase squirrel-cage high voltage and high efficiency motors series Sh with cast-iron housing.</p> <p>High voltage motors with module construction (steel/welded housing) series Sf (-E), Sfw, Sfr.</p>	<p>from 160kW up to 6000kW</p>	<p>for general industrial use, drives used for own needs of power plants (pumps, fans, coal mills, conveyors)</p>
BRAKE MOTORS	<p>Three-phase and single-phase brake motors with AC and DC brakes</p>	<p>from 0,04kW up to 160kW</p>	<p>for applications with high safety requirements or where immediate stopping of the drive is required e.g.: theatres, concert, halls, lifts, platforms, etc.</p>
MOTORS WITH FORCED VENTILATION	<p>Three-phase induction motors with forced ventilation</p>	<p>from 0,06kW up to 2500kW</p>	<p>for variable frequency drives with very wide speed regulation</p>
EXPLOSION-PROOF MOTORS	<p>Increased safety motors</p>	<p>from 0,06kW up to 22kW</p>	<p>adapted for operation in areas endangered by explosion (without methane)</p>
	<p>Flame-proof motors</p>	<p>from 0,55kW up to 3200kW</p>	<p>for applications in chemical and mining industry where explosive atmosphere of gases, vapours or dust can occur</p>
NEMA MOTORS	<p>Low voltage NEMA motors SIE series (in compliance with the NEMA PREMIUM requirements).</p>	<p>from 1HP up to 250HP</p>	<p>for general industrial applications like pumps (including JM and JP), fans, compressors also for Hazardous Locations (Class I Div 2, Class II Div 2) with CSA certificate</p>
TRACTION MOTORS	<p>Traction motors and traction generators.</p>	<p>from 50kW up to 1500kW</p>	<p>various traction vehicles: trams (including low-deck trams), trolleybuses, subway and locomotives</p>

Contents

General information.....	2
Efficiency of motors in the USA	2
Ratings – Tolerances	3
Standards.....	3
Insulation classification.....	4
Hazardous Locations Classification.....	5
Temperature Codes.....	6
Material of housing, end shields and feet	6
Cooling.....	7
Standard terminal box equipment.....	8
Vibration level.....	8
Noise level.....	8
Terminal box.....	9
Degree of protection IP	10
Painting and corrosivity classes.....	11
Mounting arrangements	12
NEMA Frame Letters	13
NEMA Design Letters	14
Definitions	15
Permissible shaft end loads	16
Bearing types and bearing nodes	17
JM/JP Pump Motors	18
Motors with UL (UR) certificate.....	18
Nomenclature.....	19
Frequency converter operation (VSD).....	19
Totally Enclosed Motors IP 55, f=60Hz	20
Overall and Mounting Dimensions.....	22
List of Motor parts	30
Ordering information	32
Cantoni Group – Certifications.....	33
Our approach	34
Cantoni Group, Cantoni Motor	35

Efficiency of motors in the USA

USA began to regulate efficiency of electric motors in 1992 with the “Energy Efficiency Provision” of the Energy Policy Act (EPAAct). In 1997, USA was the first country in the world to establish minimum energy performance standards (MEPS) for electric motors manufactured in or sold to USA. General-purpose motors 1HP-200HP were required to meet NEMA Energy Efficient standard (EPACT).

In June 2016, efficiency standards in the USA were increased once again with the Integral Horsepower Motor Rule (IHMR) which superseded the EISA standard. Under this final rule, almost all single-speed induction motors (including motors previously excluded from requirements) are required to meet NEMA Premium Efficiency levels.

On 10 December 2010 the EISA (Energy Independence and Security Act of 2007) increased the requirement for general-purpose motors 1HP-200HP to NEMA Premium Efficiency.

Complying with above requirements the efficiency has to be determined in accordance with the requirements given in the CSA C390-10 or IEEE Std 112-2004 (Test Method B, Input-Output With Loss Segregation) standards.

From 1 June 2016: motors with a rated output between 1HP – 500HP shall have a minimum efficiency class NEMA PREMIUM.

New efficiency requirements are valid for single speed polyphase AC induction electric motors (60Hz) with the following specifications:

- with squirrel-cage rotor
- with rated voltage up to 600V
- with rated output from 1HP up to 500HP (or kW equivalents)
- rated for continuous duty operation (NEMA MG-1) or for duty type S1 (IEC 60034-1)
- 2p=2, 4, 6, 8
- complying with performance requirements of a NEMA design A, B or C or an IEC design N or H
- with three or four digit NEMA frame size (or IEC metric equivalent), including those designs between two consecutive NEMA frame sizes (or IEC metric equivalent) or an enclosed 56 NEMA frame size (or IEC metric equivalent).

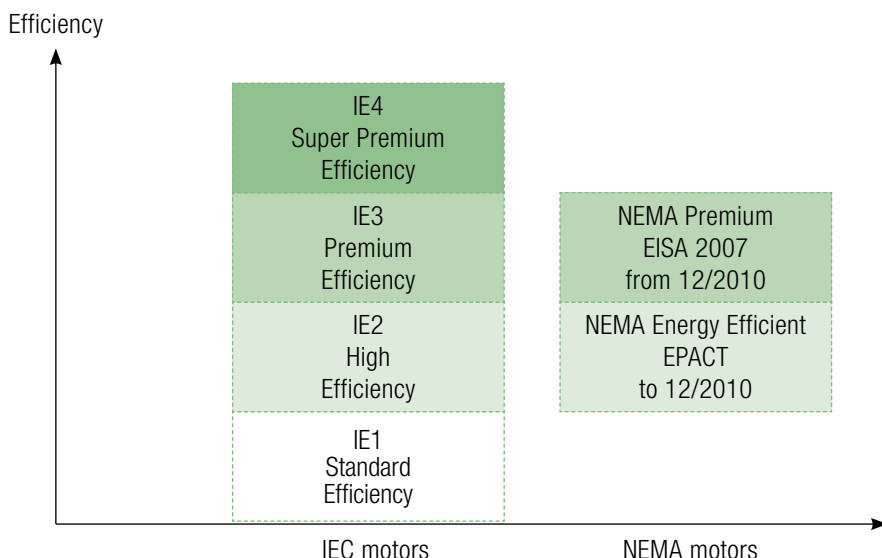

As a Manufacturer participating in the NEMA Premium Efficient Electric Motor Program, Cantoni Motor S.A. has determined that our electric motors marked with NEMA Premium Mark meet NEMA Premium Efficient Electric Motor requirements.



NEMA Premium is a certification mark of the National Electrical Manufacturers Association

Ratings – Tolerances

Tolerances of motor parameters

Permissible deviations between catalogue values and real values:

Power factor $\cos \varphi$	$\Delta \cos \varphi = -1/6 (1 - \cos \varphi_N)$
Efficiency η	NEMA PREMIUM minimum according to NEMA MG-1
Speed n	$\Delta n = \pm 20\% (n_s - n_N)$
Locked rotor current ratio I_L/I_N	$\Delta(I_L/I_N) = +20\% (I_L/I_N)$
Locked rotor torque ratio T_L/T_N	$\min (T_L/T_N) = -15\% (T_L/T_N)$ $\max (T_L/T_N) = +25\% (T_L/T_N)$
Breakdown torque ratio T_B/T_N	$\Delta(T_B/T_N) = -10\% (T_B/T_N)$
Moment of inertia J [kgm ²]	$\Delta J = \pm 10\% J$
Sound pressure level L_{pA} [dB]	$\Delta L_{pA} = +3 \text{ dB /A/}$

Tolerances of supply voltage value and frequency

Motors comply in standard with voltage value and voltage frequency variations according to the NEMA MG-1:

Voltage value U	$\Delta U = \pm 10\%$ at rated frequency
Voltage frequency f	$\Delta f = \pm 5\%$ at rated voltage

Other extended tolerances of supply voltage and their frequency are available on request.

Standards

Depending on the execution, electric motors are manufactured according to the following standards and requirements:

Motors and Generators	NEMA MG-1
General requirements – Canadian Electrical Code, Part II	CSA C22.2 No. 0
Bonding of electrical equipment	CSA C22.2 No. 0.4
Motors and generators	CSA C22.2 No. 100
Rotating Electrical Machines – General Requirements	UL 1004-1, 2 nd Edition
Nonincendive electrical equipment for use in Class I and II, Division 2 and Class III, Divisions 1 and 2 Hazardous (Classified) Locations	CSA C22.2 No. 213
Electric motors and generators for use in Hazardous (Classified) Locations	CSA C22.2 No. 145
Enclosures for use in Class II, Division 1, Groups E, F, and G Hazardous Locations	CSA C22.2 No. 25
Electric Motors and Generators for Use in Hazardous (Classified) Locations	UL Std. 674
Test Methods, Marking Requirements, and Energy Efficiency Levels for Three-Phase Induction Motors	CSA C390-10
Standard Test Procedure for Polyphase Induction Motors and Generators	IEEE 112-2004

All of our NEMA PREMIUM motors are also registered in DOE (CC number: CC117A) and Natural Resources Canada.

At the same time, our NEMA PREMIUM motors comply with European requirements – they can be CE marked.

Insulation classification

The insulation system of an electric motor is determined by a given insulation class on the basis of its thermal resistance. This thermal resistance should be guaranteed by the entire set of electric insulating materials used in the motor insulating system.

Thermal resistance classification is related to the temperature of the hotspot in the insulation occurring during rated operating conditions of the electric motor, allowing for the highest permissible rise in average temperature.

This rise should be selected so that at the highest permissible ambient temperature, the temperature of the hotspot in insulation will not exceed the value assigned to a given thermal resistance class.

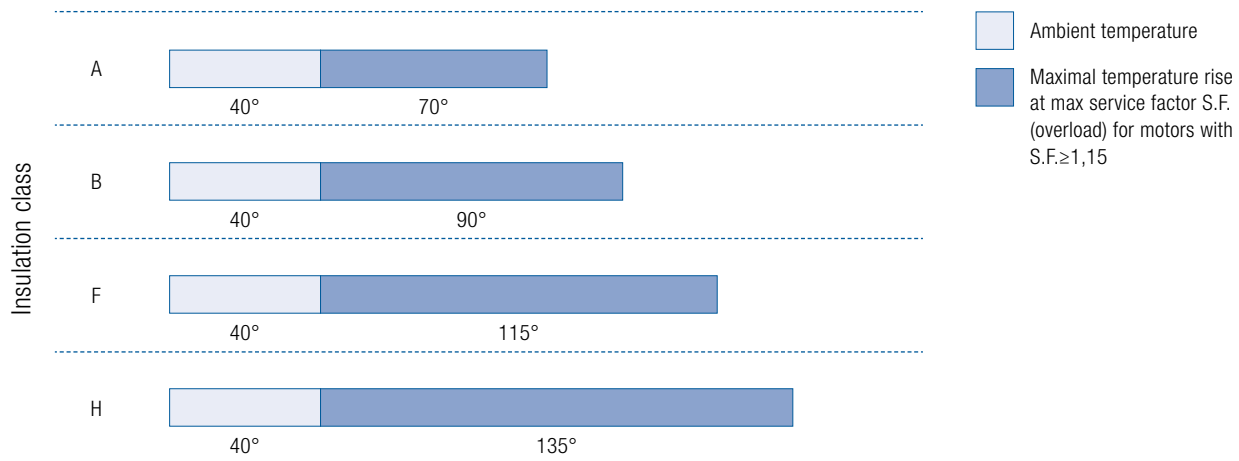

Insulation class F in an electric motor means that at ambient temperature of 40°C and max service factor S.F. (overload) the temperature rise of the winding may be max. 115°C (under specified measuring conditions in accordance with the IEEE Std 112 standard).

4

Symbols of thermal resistance classes (permissible insulation temperatures at 40°C ambient temperature)

Symbol	Temperature [°C]
A	105
B	130
F	155
H	180

SIE series Class F/B

The standard SIE NEMA motors made by Cantoni Motor in their basic version have the insulation class F while the temperature rise is limited to class B (at S.F.=1,0). This means longer life for motors.

For special request we can deliver motors equipped with insulation class H.

Strengthened insulation system gives possibility to safe operation with frequency converters – please check page 19.

Hazardous Locations Classification

Our NEMA PREMIUM motors can be delivered in special execution for Hazardous Locations and are certified for Groups A, B, C, D, F and G.

Class I Div 2 Class II Div 2

CLASS – Defines the type of hazardous material (explosive or ignitable substances).

Class I	flammable gases, vapors or liquids, such as acetylene, hydrogen, ethylene, gasoline, etc.
Class II	combustible dust such as: coke dust, grain dust, etc.
Class III	easily ignitable fibers or flyings, such as: textile, saw dust, etc.

DIVISION – Defines the likelihood of the hazardous material being present in an explosive or ignitable concentration.

DIVISION 1	hazard can exist under normal, everyday operating conditions
DIVISION 2	hazard is not likely to exist during regular operation

GROUP – Hazardous materials classification based on their ignition temperatures and explosion pressures.

Group A	acetylene	Class I
Group B	hydrogen, butadiene, ethylene oxide, propylene oxide and acrolein	
Group C	ethylene, cyclopropane and ethyl ether	
Group D	acetone, ammonia, benzene, butane, ethanol, gasoline, hexane, methane, methanol, naphtha, natural gas, propane and toluene	
Group E	combustible metal dusts: aluminum, commercial alloys and magnesium	Class II
Group F	combustible carbonaceous dusts: carbon black, charcoal, coal and coke dusts	
Group G	other combustible dusts: chemicals, flour, grain, plastic and wood	

CAUTION: Design of equipment used in the Hazardous Locations should be always chosen based on the analysis of the final application done by the user in agreement with Local Safety Authorities.

Temperature Codes

T2B

The T-Code identifies the maximum absolute motor surface temperature that will develop under any conditions of operation.

Temperature class marking	Maximum Temperature
T1	450°C (842°F)
T2	300°C (572°F)
T2A	280°C (536°F)
T2B	260°C (500°F)
T2C	230°C (446°F)
T2D	215°C (419°F)
T3	200°C (392°F)
T3A	180°C (356°F)
T3B	165°C (329°F)
T3C	160°C (320°F)
T4	135°C (275°F)
T4A	120°C (248°F)
T5	100°C (212°F)
T6	85°C (185°F)

Material of housing, end shields and feet

Frame size	Motor housing	End shields	Feet
SIE143, 145	Cast iron	Cast iron	Cast iron – integrated
SIE182, 184	Cast iron	Cast iron	Cast iron – integrated
SIE213, 215	Cast iron	Cast iron	Cast iron – integrated
SIE254, 256	Cast iron	Cast iron	Cast iron – integrated
SIE284, 286	Cast iron	Cast iron	Cast iron – screwed
SIE324, 326	Cast iron	Cast iron	Cast iron – screwed
SIE364, 365	Cast iron	Cast iron	Cast iron – screwed
SIE404, 405	Cast iron	Cast iron	Cast iron – screwed
SIE444, 445	Cast iron	Cast iron	Cast iron – screwed
SIE447	Cast iron	Cast iron	Cast iron – screwed

Cooling

General purpose motors from Cantoni Group are equipped with standard IC411 cooling. Other cooling methods (for example motors with external/separate cooling) are available on request.

IC code	Description	Drawing
IC01	<ul style="list-style-type: none"> – Open machine – Fan mounted on shaft – Often called “drip-proof” motor 	
IC410	<ul style="list-style-type: none"> – Enclosed machine – Surface cooled by natural convection and radiation – Without internal or external fan 	
IC411	<ul style="list-style-type: none"> – Enclosed machine – Smooth or finned casing – External shaft-mounted fan – Often called TEFC motor 	
IC416A	<ul style="list-style-type: none"> – Enclosed machine – Smooth or finned casing – External motorized axial fan integrated with the motor 	
IC416R	<ul style="list-style-type: none"> – Enclosed machine – Smooth or finned casing – External motorized radial fan integrated with the motor 	
IC611	<ul style="list-style-type: none"> – Enclosed machine – Heat Exchanger fitted – Two separate air circuits – Shaft-mounted Fans – Often called CacA motor 	

Standard terminal box equipment

Motor frame size	Number of supply leads	Number of threaded inlet holes	Size of threaded inlet holes [inch]	Optional rotation of terminal box	Temperature sensors in the winding	Thermal protection of bearings
143, 145	9	1	0.75	180°	on request	no
182, 184	9	1	1	180°	on request	no
213, 215	12	1	1	180°	on request	on request
254, 256	12	1	1.25	180°	on request	on request
284, 286	12	1	1.5	180°	on request	on request
324, 326	12	1	2	4x90°	3xPTC	on request
364, 365	12	1	3	4x90°	3xPTC	on request
404, 405	12	1	3	4x90°	3xPTC	on request
444, 445, 447	12	2	3	4x90°	3xPTC	on request

Vibration level

The rotors balancing method guarantees that standard vibration level of motors is much lower than required for general industrial motors according to NEMA MG-1 (0.15in/s). On customer's demand the motors can be produced with even more reduced vibration level.

Vibration level in standard and reduced execution:

Vibration level	Mounting	in/s
Standard	Resiliently	0.087
	Rigid	0.071
Reduced	Resiliently	0.043
	Rigid	0.035

Remark:

Limits stated in the table mentioned above are applicable for uncoupled (disconnected from the driven machine) and operating at no load motors.

Noise level

Motors in standard comply with a permissible sound power level according to NEMA MG-1.

On customer's demand the motors can be delivered with reduced noise level by using special cooling systems or additional external sound-absorbing covers.

Terminal box

The standard mounting position for NEMA motors is F1 – the terminal box is located on the left side of the motor facing the output shaft and it is equipped with 9 (size 143T...184T) or 12 (size 213T...447T) supply leads (without terminal block).

Our NEMA PREMIUM motors are also available with terminal box on right side (F2) or on top (F3).

As standard, motors are offered with aluminium terminal box for sizes 143–286, and cast iron for sizes 320–440.

As optional execution, for sizes 143–286 can be also cast iron terminal box.

Basic Connection Diagrams

Connection diagram of 143T÷184T motors, nominal voltage 230/460V

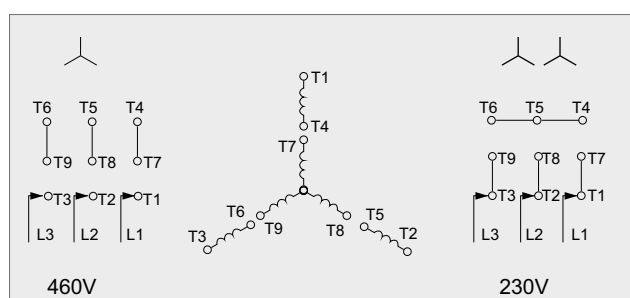

Connection diagram of 213T÷447T motors, nominal voltage 230/460V

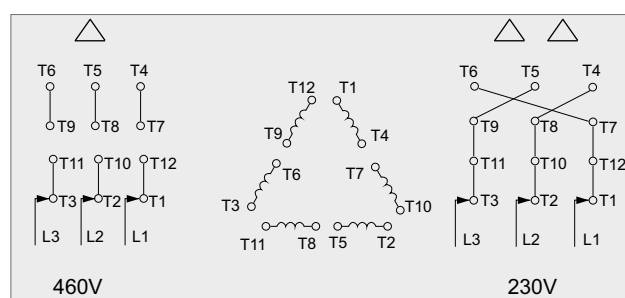

Motors in 230V/460V execution are capable of Part Winding Starting (PWS).

Connection diagram of 143T÷447T motors, in special execution with nominal voltage 575V – 3 or 6 supply leads

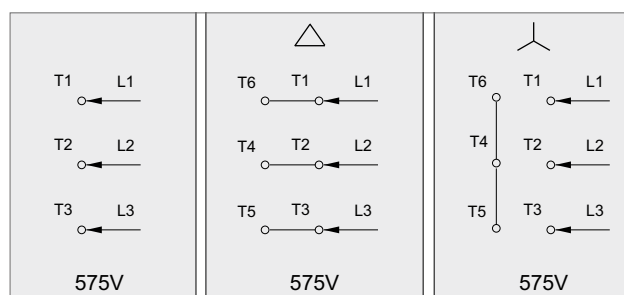







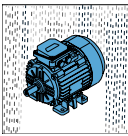

Degree of protection IP

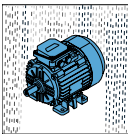
IP 55

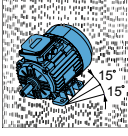
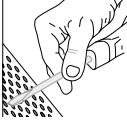
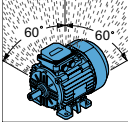
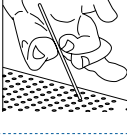
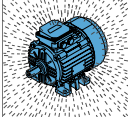
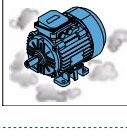
Standard degree of protection of our NEMA Premium general purpose and Class I Div 2 motors is IP55.
Class II Div 2 motors comply with requirements of IP66.

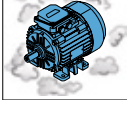
IP 66

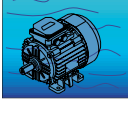
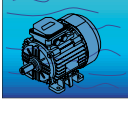
Protection against penetration of solid matter			Protection against penetration of fluids		
1st digit	Description		2nd digit	Description	
0	 Not protected		0	 Not protected	
1	 Protected against solid bodies larger than 50 mm		1	 Protected against vertically falling drops of water	
2	 Protected against solid bodies larger than 12 mm		2	 Protected against vertically falling drops of water up to 15°	
3	 Protected against solid bodies larger than 2,5 mm		3	 Protected against rain up to 60°	
4	 Protected against solid bodies larger than 1 mm		4	 Protected against rain falling from any direction	
5	 Protected against deposition of dust		5	 Protected against sprayed water from any direction	
6	 Totally protected against deposition of dust		6	 Protected against temporary immersion	
			7	 Protected against immersion between 0,15 and 1 m	
			8	 Protected against immersion at preset pressure and time	

Motors size 143 to 286 are equipped with seal rings (Simmerring or V-ring) on drive side and on non drive side. Labyrinth seals protect the motors from size 324 and above. The terminal box is sealed with a gasket.

Higher degree of protection is available on request.

Painting and corrosivity classes

Standard painting system with RAL5010 color used in all our motors comply with C3 corrosion class according to ISO 12944.

For special request motors can be painted with other colors and with alternative painting systems (up to C5M corrosion class).

RAL 5010/C3



Corrosion class	Environment	
	Interior	Exterior
C1 (very low)	Heated buildings with a clean atmosphere such as hotels, offices, shops, schools.	N/A
C2 (low)	Unheated buildings, where condensation may occur e.g. storehouses, sports halls.	Atmosphere contaminated to a small extent, mostly rural regions.
C3 (medium)	Production space of high humidity and certain air contamination e.g. foodstuff plants, laundries, breweries, dairies.	Industrial and urban atmosphere with an average Sulphur oxide (IV) contamination level. Inshore areas of low salinity.
C4 (high)	Chemical plants, swimming pools, ship repair yards.	Industrial areas and inshore areas of medium salinity.
C5I (very high – industrial)	Buildings and areas of almost constant condensation and high contamination.	Industrial areas of high humidity and aggressive atmosphere.
C5M (very high – marine)	Buildings and areas of almost constant condensation and high contamination.	Coast and offshore areas with high salt content.

Mounting arrangements

According to the NEMA MG-1 standard

NEMA Floor Mountings

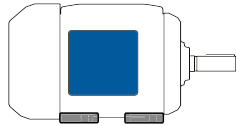

F1 ASSEMBLY

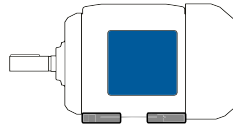

F2 ASSEMBLY

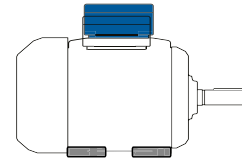

F3 ASSEMBLY

NEMA Wall Mountings

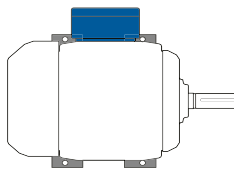

W1 ASSEMBLY

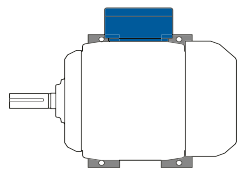

W2 ASSEMBLY

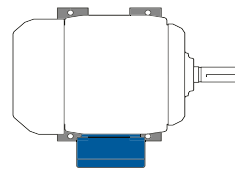

W3 ASSEMBLY

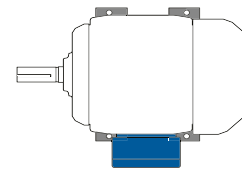

W4 ASSEMBLY

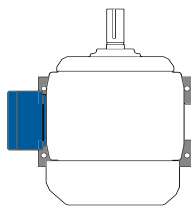

W5 ASSEMBLY

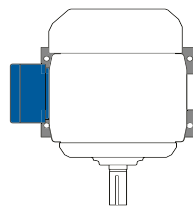

W6 ASSEMBLY

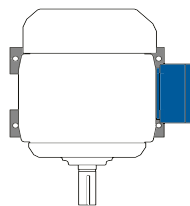

W7 ASSEMBLY

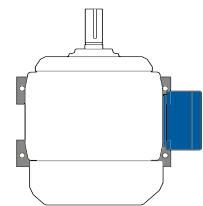

W8 ASSEMBLY

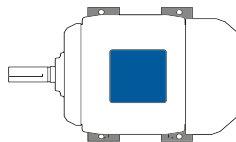

W9 ASSEMBLY

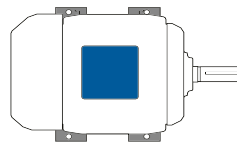

W10 ASSEMBLY

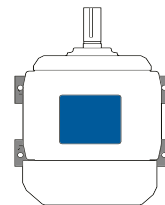

W11 ASSEMBLY

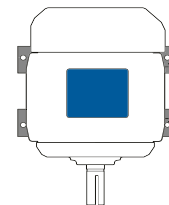

W12 ASSEMBLY

NEMA Ceiling Mountings

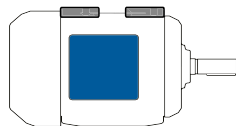

C1 ASSEMBLY

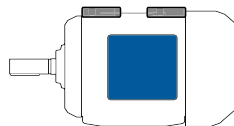

C2 ASSEMBLY

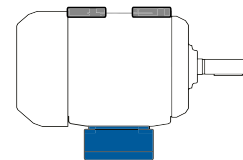

C3 ASSEMBLY

In standard, motors are offered in F1 execution – other mounting arrangements are available on request.
 Cantoni NEMA Premium motors frames 143 up to 286 can be easily converted from F1 to F2 terminal box position by housing rotation.
 Additionally, motors frames 284 up to 447 can be converted to round body by removing screwed feet.

NEMA Frame Letters

Our SIE NEMA PREMIUM motors are offered in different executions marked in motor type with proper Frame Letters according to NEMA MG-1 requirements: C, D, JM, JP and S. Frame Letter T is our standard execution. Other special executions of motors are available on request.

C-face D-flange

Frame letters according to NEMA MG-1:

Letter	Definition
A	Industrial direct-current machine
B	Carbonator pump motors (see NEMA MG-1, 18.270–18.281)
C	Type C face mounting on drive end
CH	Face mounting dimensions are different from those for the frame designator having the suffix letter „C”
D	Type D flange mounting on drive end
E	Shaft extension dimensions for elevator motors in frames larger than 326T frames
FC	Face mounting on opposite drive end
G	Gasoline pump motors (see NEMA MG-1, 18.91)
H	Indicates a small machine having an „F” dimension larger than that of the same frame without the suffix letter „H” (See NEMA MG-1, 4.4.1 and 4.5.1)
HP, HPH	Type P flange-mounted, vertical solid-shaft motors having dimensions in accordance with NEMA MG1-1, 18.252
J	Jet pump motors (see NEMA MG1-1, 18.132)
JM	Face-mounted, close-coupled pump motor having antifriction bearings and dimensions in accordance with Table 1 of MG-1, 18.250
JP	Type C face-mounted, close-couple pump motor having antifriction bearings and dimensions in accordance with Table 2 of MG-1, 18.250
K	Sump pump motors (see NEMA MG-1, 18.78)
LP, LPH	Type P flange-mounted, vertical solid-shaft motors having dimensions in accordance with MG-1, 18.251
M	Oil burner motors (see NEMA MG-1, 18.106)
N	Oil burner motors (see NEMA MG-1, 18.106)
P, PH	Type P flange-mounted, vertical hollow-shaft motors having dimensions in accordance with NEMA MG-1, 18.238
R	Drive end tapered shaft extension having dimensions in accordance with NEMA MG-1, 4.4.2
S	Standard short shaft for direct connection
T	Included as part of a frame designation for which standard dimensions have been established
U	Previously used as part of a frame designation for which standard dimensions had been established
V	Vertical mounting only
VP	Type P flange-mounted, vertical solid-shaft motors having dimensions in accordance with NEMA MG-1, 18.237
X	Wound-rotor crane motors with double shaft extension (see NEMA MG-1, 18.229 and 18.230)
Y	Special mounting dimensions
Z	All mounting dimensions are standard except the shaft extension(s). It is also used to designate double shaft extension.

NEMA Design Letters

Standard definitions for design A, B, C and D. The letter designation describes the torque and current characteristics of the motors.

Design A or B

	Locked Rotor Torque [%]	Pull Up Torque [%]	Breakdown Torque [%]	Slip	Typical applications	Features
NEMA DESIGN A	70-275	65-190	175-300	<5%	Fans, blowers, centrifugal pumps and compressors, motorgenerator sets, etc. where starting torque requirements are relatively low	Have normal starting torques but high starting currents. This is useful for applications with brief heavy overloads.
NEMA DESIGN B	70-275	65-190	175-300	<5%	Fans, blowers, centrifugal pumps and compressors, motorgenerator sets, etc. where starting torque requirements are relatively low	Have normal starting torque combined with a low starting current. This motors have sufficient locked rotor torques to start a wide variety of industrial applications.
NEMA DESIGN C	200-285	140-195	190-225	<5%	Conveyors, crushers, stirring motors, agitators, resiprocating pumps and compressors, etc., where starting under load is required	Have high starting torques with low starting currents. These motors are designed for starting heavy loads due to their high, locked rotor torques.
NEMA DESIGN D	275	N/A	N/A	≥5%	High peak loads with or without flywheels such as punch presses, shears, elevators, winches, hoists, oil-well pumping and wire drawing motors	Have high starting torques and low starting current, however, they feature high slip. This reduces power peaks in the event that peak power is encountered, motor slip will increase.

Torque vs Speed Characteristics

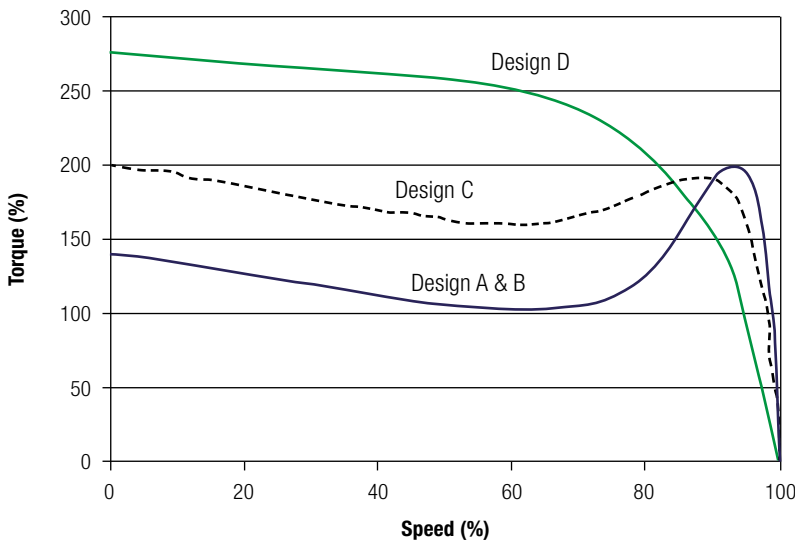

Relative torque characteristics of NEMA Design A, B, C, D motors

Cantoni NEMA Premium motors fulfil and even exceed (torque values) requirements for Design A, B or C. Other Design types are available upon request.

Definitions

Relation between rated output power and rated torque on motor shaft:

$$T = \frac{5252 \times P}{n}$$

where:

- T [Lbft] is rated output torque on motor shaft
- P [HP] is rated output power on motor shaft
- n [rpm] is rated speed of motor shaft

Relation between rated output power on shaft and rated consumed power from mains:

$$P_1 = \frac{745,6 \times P}{\eta} \times 100$$

where:

- P_1 [W] is rated consumed power from mains by motor
- P [HP] is rated output power on motor shaft
- η [%] is rated efficiency of motor

Relation between rated consumed power from mains and rated voltage, current, power factor:

$$P_1 = \sqrt{3} \times U \times I \times \cos\varphi$$

where:

- P_1 [W] is rated consumed power from mains by motor
- U [V] is rated supply voltage of motor
- I [A] is rated current consumed from mains by motor
- $\cos\varphi$ is rated power factor of motor

Units of measurement

Parameter name	Symbol	Unit name	Symbol
Frequency	f	Hertz	Hz
Active power	P_1	Watt	W
Shaft power	P	Horse Power	HP
Voltage	U	Volt	V
Electric Current	I	Amper	A
Power factor	$\cos\varphi$	N/A	N/A
Resistance	R	Ohm	Ω
Sound power level	L_{WA}	decibel	dB
Sound pressure level	L_{PA}	decibel	dB

Permissible shaft end loads

Frame size	Number of poles	Horizontal operation		Vertical operation			Frame size	Number of poles	Horizontal operation		Vertical operation		
		$F_R(x=0)$	$F_R(x=\max)$	F_P	F_{a1}	F_{a2}			$F_R(x=0)$	$F_R(x=\max)$	F_P	F_{a1}	F_{a2}
		[kN]		[kN]					[kN]		[kN]		
SIE 143, 145	2	0,79	0,66	0,64	0,44	0,84	SIE364TS	2	3,08	2,66	2,38	1,78	3,16
	4	1,00	0,83	0,80	0,65	1,05	SIE364T	4	3,67	2,95	2,94	2,05	4,09
	6	1,15	0,95	0,90	0,77	1,17		6	4,15	3,33	3,72	2,61	5,17
SIE 182, 184	2	1,56	1,22	1,23	0,84	1,60	SIE365TS	2	2,91	2,52	2,33	1,66	3,2
	4	1,92	1,58	1,50	1,19	1,96	SIE365T	4	3,46	2,78	2,88	1,88	4,16
	6	2,20	1,80	1,69	1,26	2,20		6	3,98	3,2	3,66	2,47	5,25
SIE 213, 215	2	2,11	1,65	1,82	0,98	2,37	SIE404T	6	5,15	4,05	4,13	2,63	6,07
	4	2,67	2,08	2,31	1,36	3,00	SIE405TS	2	3,84	3,31	2,94	2,17	3,93
	6	3,06	2,39	2,51	1,40	3,26	SIE405T	4	4,23	3,32	3,53	2,15	5,31
SIE 254, 256	2	2,43	1,88	1,97	1,00	2,56		6	4,92	3,87	4,07	2,41	6,19
	4	3,06	2,38	2,54	1,43	3,31	SIE444TS	2	3,44	2,98	2,83	1,65	4,35
	6	3,54	2,81	2,83	1,80	3,68	SIE444T	4	5,71	4,48	4,55	2,88	6,68
SIE 284, 286	2	2,61	2,13	2,20	1,00	2,87		6	6,46	5,07	3,35	1,34	5,9
	4	3,30	2,68	2,83	1,37	3,68	SIE445TS	2	3,25	2,81	2,77	1,49	4,43
	6	3,78	3,07	3,17	1,93	4,12	SIE445T	4	5,33	4,18	4,44	2,54	6,88
SIE324TS	2	2,86	2,45	2,14	1,68	2,74		6	5,95	4,66	5,04	2,69	8,05
SIE324T	4	3,36	2,72	2,63	1,93	3,53	SIE447TSA	2	2,87	2,53	2,74	1,22	4,66
	6	3,96	3,21	3,37	2,62	4,38	SIE447TA	4	4,66	3,74	4,25	1,85	7,35
SIE326TS	2	2,73	2,34	2,1	1,58	2,78	SIE447TSB	2	2,3	2,02	2,4	0,57	4,69
SIE326T	4	3,11	2,52	2,55	1,73	3,63	SIE447TB	4	4,09	3,34	4,08	1,28	7,72
	6	3,87	3,14	3,35	2,55	4,41							

Value of radial force F_R acting on the shaft end for a given belt pulley diameter is calculated according to the following formula:

$$F_R = \frac{19\,600 \times P \times k}{D_k \times n} \text{ [N]}$$

where: P – motor output [kW]
 D_k – belt pulley diameter [m]
 n – speed [rpm]
 k – belt tension factor:
 for V-belts $k=2,2$
 for flat belts $k=3$

Value of force F_R acting on any point of the shaft end (between points $X=\max$ and $X=0$) may be calculated according to the following formula:

$$F_R = F_{x0} - \frac{X}{E} \times (F_{x0} - F_{xMAX}) \text{ [N]}$$

where: F_{x0} – value of F_R force acting on the beginning of the shaft end
 F_{xMAX} – value of F_R force acting on the end of the shaft end
 E – length of the shaft end

Bearing types and bearing nodes

Frame size	Number of poles	Bearings	Frame size	Bearings lubrication on the run
143, 145	2÷6	6205 2Z C3	143, 145	no
182, 184	2÷6	6206 2Z C3	182, 184	no
213, 215	2÷6	6308 2Z C3/ 6306 2Z C3	213, 215	on request
254, 256	2÷6	6309 2Z C3	254, 256	on request
284, 286	2÷6	6311 2Z C3	284, 286	on request
324, 326	2÷6	6312 C3	324, 326	yes
364, 365	2÷6	6313 C3	364, 365	yes
404, 405	2÷6	6315 C3	404, 405	yes
444, 445, 447	2	6315 C3	444, 445, 447	yes
444, 445, 447	4-6	6318 C3		

Frame size
SIE143 ÷ 286

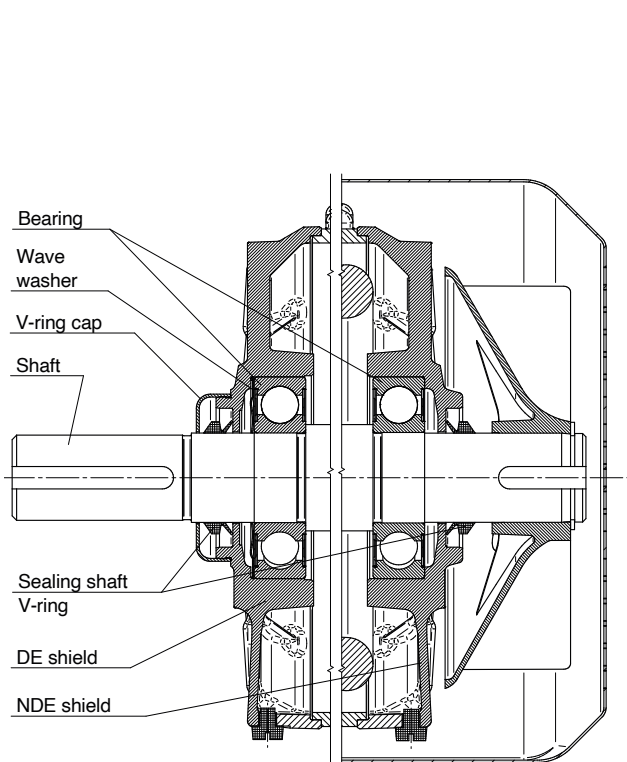

Frame size
SIE324 ÷ 447

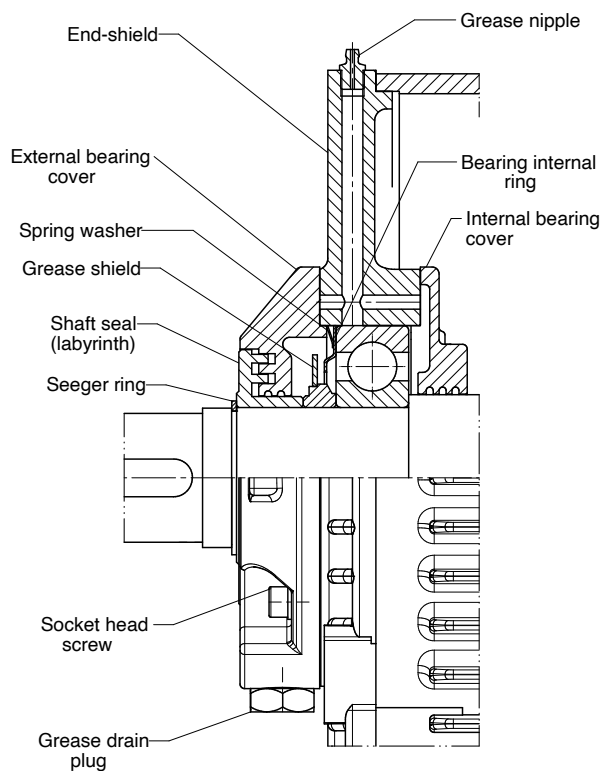

JM/JP Pump Motors

Three-phase JM/JP Pump Motors are designed for use with close-coupled pumps having NEMA JP or JM mounting end shaft dimensions. In such applications, the pump impeller is mounted directly on the motor shaft. All motors are designed for continuous duty service.

JM pump motors are available in frame sizes 143 up to 326 and JP pump motors are available in frame sizes from 143 up to 365 according to standard NEMA MG-1.

Except for dimensions, all motor features and electrical parameters of JM/JP pump motors offered by Cantoni Group are the same as in standard NEMA Premium motors.



Motors with UL (UR) certificate

We can deliver our SIE NEMA PREMIUM motors designed and produced according to UL requirements delivered with Certificate Of Compliance.



CERTIFICATE OF COMPLIANCE

Certificate Number	20160630 – E233211
Report Reference	E233211 - 20111214
Issue Date	2016-JUNE-30

Issued to:	CANTONI MOTOR SA ul 3 Maja 28 43-400 Cieszyn, POLAND
-------------------	--

This is to certify that representative samples of	Motors - Component (See following page for additional model information.)
--	--

Have been investigated by UL in accordance with the Standard(s) indicated on this Certificate.

Standard(s) for Safety:	ANSI/UL 1004-1, "Rotating Electrical Machines - General Requirements" and CSA-C22.2 No. 100, "Motors and Generators."
--------------------------------	---

Additional Information:	See the UL Online Certifications Directory at www.ul.com/database for additional information
--------------------------------	---

Only those products bearing the UL Certification Mark should be considered as being covered by UL's Certification and Follow-Up Service.

The UL Recognized Component Mark generally consists of the manufacturer's identification and catalog number, model number or other product designation as specified under "Marking" for the particular Recognition as published in the appropriate UL Directory. As a supplementary means of identifying products that have been produced under UL's Component Recognition Program, UL's Recognized Component Mark: may be used in conjunction with the required Recognized Marks. The Recognized Component Mark is required when specified in the UL Directory preceding the recognitions or under "Markings" for the individual recognitions.

Recognized components are incomplete in certain constructional features or restricted in performance capabilities and are intended for use as components of complete equipment submitted for investigation rather than for direct separate installation in the field. The final acceptance of the component is dependent upon its installation and use in complete equipment submitted to UL LLC.

Look for the UL Certification Mark on the product.

Bruce Maheshwari, Director North American Certification Program
UL LLC
Any information and documentation involving UL Mark services are provided on behalf of UL LLC (UL) or any authorized licensee of UL. For questions, please contact a local UL Customer Service Representative at <http://ul.com/customer-service>

In order to see Cantoni Motor's current range of UL certified products, you can log into UL Product iQ™ database at <https://productiq.ulprospector.com/>.

Nomenclature

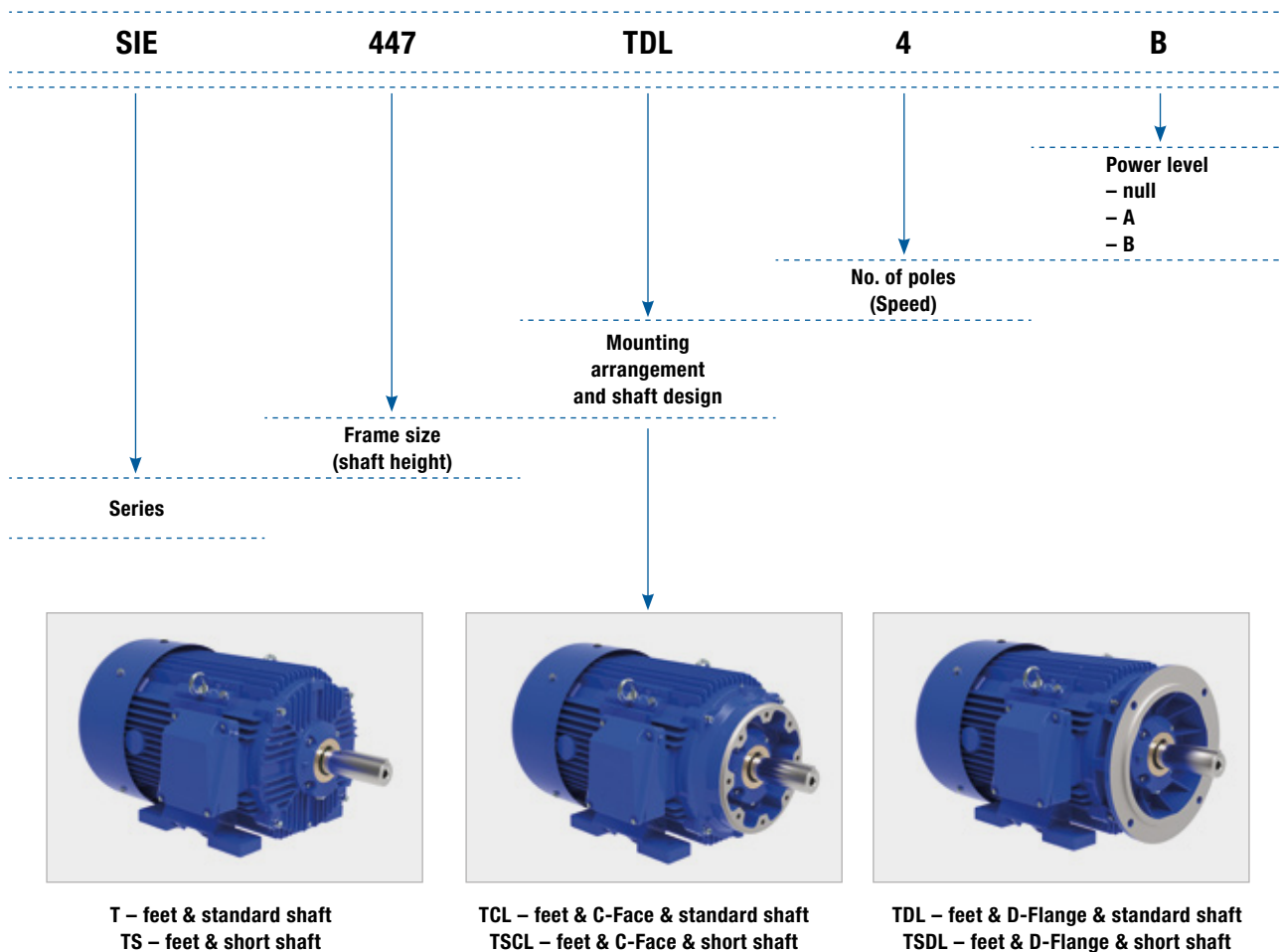

Frequency converter operation (VSD)

Electronic speed control is carried out using a frequency converter (VSD) that adjusts the speed of the motor – and therefore the torque produced – based on the energy needed.

Motor size	SIE143-286	SIE324-444	SIE445-447
In standard designed for frequency converter supply	Yes	Yes	Yes
Permissible output parameters of the frequency converter (measured on motor terminals – including supply cable between motor and frequency converter):		$U_{peak} \leq 1,35kV$ $t_r \geq 0,8\mu s$	
Insulated bearing or bearing chamber on NDE-side	N/A	Available on request	Recommended in motors designed for frequency converter supply with rated power >125HP
Speed control range	Permissible speed control range will depend on the application (load curve) and parameters of the frequency converter thus it should be established individually.		

Totally Enclosed Motors IP55 f=60Hz

Item	Type	Rated power		Rated torque	Rated Efficiency [%]			Power factor			Current Amps at 460V		Current Amps at 575V		Locked rotor torque ratio	Breakdown torque ratio	NEMA Code Letter	Wk ²	Service factor	Net Weight
		HP	RPM		Lbft	50% load	75% load	100% load	50% load	75% load	100% load	Full load [A]	Locked rotor [A]	Full load [A]						
RPM=3600 min-1																				
1	SIE 143T2	1.5	3540	2.2	79.8	83.2	84.0	0.57	0.69	0.78	2.1	20.0	1.7	16.0	350	410	M	0.07	1.4	56
2	SIE 145T2	2	3525	3.0	83.3	85.7	85.5	0.62	0.75	0.82	2.7	25.4	2.2	20.3	360	400	L	0.08	1.4	57
3	SIE 182T2	3	3500	4.5	84.4	86.4	86.5	0.65	0.76	0.82	4.0	32.0	3.2	25.6	310	320	K	0.12	1.4	76
4	SIE 184T2	5	3535	7.4	86.7	88.6	88.5	0.68	0.80	0.85	6.2	73.0	5.0	58.4	450	530	N	0.2	1.4	102
5	SIE 213T2	7.5	3525	11.2	88.7	90.0	89.5	0.81	0.89	0.92	8.5	76.0	6.8	60.8	290	315	K	0.45	1.3	159
6	SIE 215T2	10	3535	14.8	89.3	90.4	90.2	0.80	0.88	0.91	11.4	93.0	9.1	74.4	300	335	J	0.5	1.3	173
7	SIE 254T2	15	3540	22.3	90.5	91.8	91.7	0.77	0.85	0.87	17.6	112	14.1	90.0	240	250	G	1.15	1.3	258
8	SIE 256T2	20	3540	29.7	91.7	92.4	91.7	0.82	0.88	0.89	22.9	138	18.3	110	230	260	F	1.47	1.3	306
9	SIE 284TS2	25	3555	36.9	91.3	92.4	92.4	0.74	0.82	0.86	29.5	205	23.6	164	260	300	H	1.72	1.2	348
10	SIE 286TS2	30	3540	44.5	91.2	92.0	91.7	0.80	0.85	0.87	35.2	215	28.2	172	250	300	G	1.92	1.2	390
11	SIE 324TS2	40	3552	59	92.7	93.0	92.4	0.88	0.91	0.92	44.0	290	35.0	234	145	200	G	4.0	1.2	608
12	SIE 326TS2	50	3552	74	93.5	93.7	93.0	0.89	0.92	0.92	55.0	362	44.0	290	145	200	G	4.7	1.2	655
13	SIE 364TS2	60	3562	88.5	93.8	94.1	93.6	0.87	0.91	0.92	65.0	435	52.0	348	125	200	G	6.5	1.2	860
14	SIE 365TS2	75	3560	111	94.2	94.3	93.6	0.89	0.91	0.92	82.0	545	65.0	435	120	200	G	7.9	1.2	933
15	SIE 405TS2	100	3565	147	95.3	95.6	95.4	0.83	0.88	0.90	109	725	87.0	580	170	240	G	10.0	1.2	1058
16	SIE 444TS2	125	3578	184	95.1	95.3	95.0	0.86	0.90	0.92	134	956	107	768	140	260	G	22.5	1.2	1488
17	SIE 445TS2	150	3578	220	95.2	95.3	95.0	0.86	0.91	0.92	161	1192	129	955	160	270	G	28.4	1.2	1594
18	SIE 447TS2A	200	3578	294	95.8	95.8	95.4	0.88	0.92	0.93	211	1507	169	1206	150	250	G	29.1	1.2	2161
19	SIE 447TS2B	250	3579	367	96.1	96.2	95.8	0.89	0.92	0.93	263	1912	210	1528	180	270	G	36.9	1.2	2271
RPM=1800 min-1																				
20	SIE 143T4	1	1765	3	81.3	84.5	85.5	0.57	0.70	0.78	1.4	12.9	1.1	10.3	300	320	M	0.09	1.4	53
21	SIE 145T4	1.5	1750	4.5	85.0	86.8	86.5	0.59	0.72	0.79	2.1	16.6	1.6	13.3	300	400	K	0.1	1.4	57
22	SIE 145T4	2	1745	6	85.8	87.1	86.5	0.64	0.77	0.83	2.6	19.2	2.1	15.4	260	340	J	0.13	1.4	59
23	SIE 182T4	3	1775	8.9	85.8	88.5	89.5	0.54	0.67	0.75	4.2	38.0	3.4	30.4	320	400	M	0.27	1.4	102
24	SIE 184T4	5	1770	14.8	87.6	89.2	89.5	0.58	0.71	0.78	6.7	61.0	5.4	48.8	300	380	L	0.34	1.3	108
25	SIE 213T4	7.5	1765	22.3	90.5	91.6	91.7	0.67	0.78	0.82	9.3	71.0	7.4	56.8	240	290	J	0.87	1.3	167
26	SIE 215T4	10	1770	29.6	90.4	91.7	91.7	0.66	0.77	0.82	12.5	87.0	10.0	69.6	230	280	H	0.99	1.3	185
27	SIE 254T4	15	1775	44.3	90.7	92.0	92.4	0.76	0.84	0.88	17.3	168	13.8	134.4	380	440	K	2.89	1.3	301
28	SIE 256T4	20	1775	59.1	91.4	92.7	93.0	0.76	0.84	0.88	22.9	230	18.3	184	380	450	L	3.57	1.2	390
29	SIE 284T4	25	1780	73.7	91.6	93.1	93.6	0.66	0.76	0.82	30.5	300	24.4	240	380	420	L	3.59	1.2	397
30	SIE 286T4	30	1780	88.4	91.3	93.0	93.6	0.61	0.73	0.80	37.5	350	30.0	280	370	390	L	3.84	1.2	441
31	SIE 324T4	40	1780	118	94.3	94.7	94.1	0.78	0.86	0.88	45.0	290	36.0	232	240	270	G	9.3	1.3	690
32	SIE 326T4	50	1781	148	94.9	95.1	94.5	0.78	0.85	0.88	56.0	362	45.0	290	250	270	G	11.6	1.3	769
33	SIE 364T4	60	1786	177	95.3	95.6	95.0	0.80	0.87	0.88	67.0	435	54.0	348	140	200	G	15.5	1.2	926
34	SIE 365T4	75	1787	221	95.5	95.8	95.4	0.80	0.86	0.88	84.0	542	67.0	434	150	210	G	17.8	1.2	1012
35	SIE 405T4	100	1785	294	95.7	95.9	95.4	0.84	0.89	0.91	108	790	86.0	632	220	230	G	29.8	1.2	1241
36	SIE 444T4	125	1788	367	95.7	95.8	95.4	0.85	0.89	0.90	136	909	109	726	175	210	G	42.9	1.2	1662
37	SIE 445T4	150	1788	441	96.1	96.2	95.8	0.86	0.90	0.91	161	1085	129	868	180	200	G	52.7	1.2	1823
38	SIE 447T4A	200	1790	587	96.2	96.7	96.5	0.81	0.87	0.89	218	1550	174	1240	170	200	G	68.0	1.2	2310
39	SIE 447T4B	250	1788	735	96.5	96.6	96.2	0.85	0.90	0.91	267	1825	214	1460	160	200	G	81.5	1.2	2447

We offer special JM pump motors up to frame size 326 and JP pump motors up to frame size 365.

Totally Enclosed Motors IP55 f=60Hz

Item	Type	Rated power			Rated speed			Rated torque			Rated Efficiency [%]			Power factor			Current Amps at 460V		Current Amps at 575V		Locked rotor torque ratio	Breakdown torque ratio	NEMA Code Letter	WK ²	Service factor	Net Weight
		HP	RPM	Lbft	50% load	75% load	100% load	50% load	75% load	100% load	Full load [A]	Locked rotor [A]	Full load [A]	Locked rotor [A]	%	%	-	Lb-Ft ²	-	Lbs						
RPM=1200 min-1																										
40	SIE 145T6	1	1160	4.5	78.6	81.9	82.5	0.46	0.59	0.68	1.7	10.0	1.4	8.0	240	300	K	0.15	1.4	55						
41	SIE 182T6	1.5	1170	6.7	84.5	86.9	87.5	0.47	0.59	0.68	2.4	14.0	1.9	11.2	190	280	J	0.4	1.4	85						
42	SIE 184T6	2	1170	9.0	86.9	88.6	88.5	0.51	0.64	0.72	3.0	25.0	2.4	20.0	200	300	L	0.45	1.4	98						
43	SIE 213T6	3	1165	13.5	88.0	89.5	89.5	0.56	0.68	0.74	4.2	32.0	3.4	25.6	260	360	K	1.45	1.4	205						
44	SIE 215T6	5	1170	22.4	88.2	89.6	89.5	0.57	0.69	0.75	7.0	46.0	5.6	36.8	250	350	J	1.56	1.3	220						
45	SIE 254T6	7.5	1185	33.2	88.6	90.6	91.0	0.54	0.67	0.74	10.4	77.5	8.3	62.0	320	350	K	2.63	1.3	321						
46	SIE 256T6	10	1180	44.5	89.2	90.8	91.0	0.58	0.70	0.77	13.4	94.0	10.7	75.2	290	330	J	3.31	1.3	363						
47	SIE 284T6	15	1185	66.4	89.0	91.2	91.7	0.61	0.73	0.79	19.5	180	15.6	144	470	380	L	5.19	1.3	371						
48	SIE 286T6	20	1185	88.5	89.1	91.1	91.7	0.63	0.74	0.80	25.5	221	20.4	177	380	320	L	6.03	1.2	421						
49	SIE 324T6	25	1190	110	92.4	93.3	93.0	0.65	0.75	0.80	31.5	182	25	146	230	240	G	12.9	1.3	653						
50	SIE 326T6	30	1190	132	92.6	93.3	93.0	0.69	0.78	0.82	37.0	217	30	174	230	240	G	14.7	1.3	681						
51	SIE 364T6	40	1192	176	93.5	94.2	94.1	0.68	0.78	0.82	48.5	290	39	232	180	210	G	23.1	1.3	917						
52	SIE 365T6	50	1191	221	93.7	94.3	94.1	0.71	0.80	0.83	60.0	362	48	290	170	200	G	25.9	1.3	970						
53	SIE 404T6	60	1192	264	93.7	94.4	94.5	0.68	0.78	0.82	72.0	435	58	348	180	200	G	36.8	1.3	1127						
54	SIE 405T6	75	1191	331	94.4	94.9	94.5	0.70	0.79	0.82	91.0	542	73	434	140	200	G	41.9	1.2	1210						
55	SIE 444T6	100	1192	441	93.9	94.9	95.0	0.65	0.75	0.80	123	725	98	580	190	200	G	64.1	1.2	1726						
56	SIE 445T6	125	1192	551	95.3	95.6	95.4	0.67	0.77	0.80	153	910	122	728	190	200	G	76.3	1.2	1931						

We offer special JM pump motors up to frame size 326 and JP pump motors up to frame size 365.

Overall and Mounting Dimensions

Rigid Base

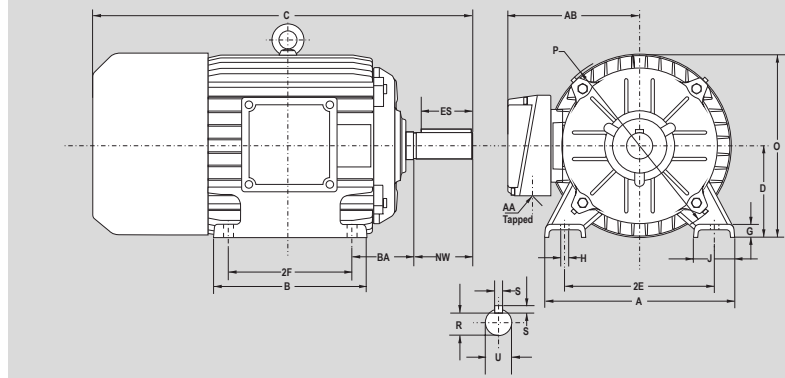

Motor Type	Mounting Dimensions (inches)											Overall Dimensions (inches)							
	Shaft End											A	AA	AB	B	C	J	O	P
	D	2E	2F	G	H	BA	ES	N-W	R	S	U								
SIE 143T	3.50	5.50	4.00	0.39	0.34	2.25	1.52	2.25	0.771	0.188	0.875	6.62	3/4	6.5	5.83	14.2	1.66	7.48	8.27
SIE 145T	3.50	5.50	5.00	0.39	0.34	2.25	1.52	2.25	0.771	0.188	0.875	6.62	3/4	6.5	7.00	15.15	1.66	7.48	8.27
SIE 182T	4.5	7.5	4.5	0.6	0.41	2.75	1.94	2.75	0.986	0.25	1.125	9	1	7.9	8.31	17.7	2.13	9.09	9.53
SIE 184T	4.5	7.5	5.5	0.6	0.41	2.75	1.94	2.75	0.986	0.25	1.125	9	1	7.9	8.31	17.7	2.13	9.09	9.53
SIE 213T	5.25	8.5	5.5	0.67	0.41	3.5	2.55	3.38	1.201	0.312	1.375	10.24	1	8.92	8.7	22.25	2.2	10.96	11.61
SIE 215T	5.25	8.5	7	0.67	0.41	3.5	2.55	3.38	1.201	0.312	1.375	10.24	1	8.92	10.28	22.88	2.2	10.96	11.61
SIE 254T	6.25	10	8.25	0.58	0.55	4.25	3.11	4	1.416	0.375	1.625	12.28	1.25	10.08	9.92	25.83	2.36	13.18	14.17
SIE 256T	6.25	10	10	0.58	0.55	4.25	3.11	4	1.416	0.375	1.625	12.28	1.25	10.08	11.65	27.6	2.36	13.18	14.17
SIE 284T	7	11	9.5	0.89	0.55	4.75	3.53	4.62	1.591	0.5	1.875	13.78	1.5	10.34	13.11	31.16	2.75	14.01	14.17
SIE 284TS	7	11	9.5	0.89	0.55	4.75	2.1	3.25	1.416	0.375	1.625	13.78	1.5	10.34	13.11	27.2	2.75	14.01	14.17
SIE 286T	7	11	11	0.89	0.55	4.75	3.53	4.62	1.591	0.5	1.875	13.78	1.5	10.34	13.11	31.16	2.75	14.01	14.17
SIE 286TS	7	11	11	0.89	0.55	4.75	2.1	3.25	1.416	0.375	1.625	13.78	1.5	10.34	13.11	27.2	2.75	14.01	14.17

Overall and Mounting Dimensions

Rigid Base

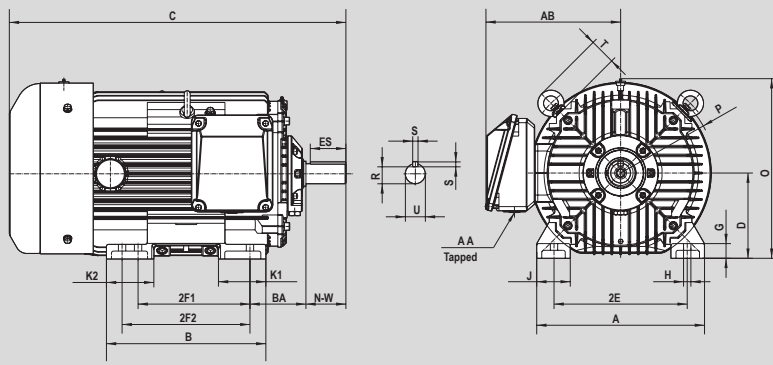

Motor Type	Mounting Dimensions (inches)													Overall Dimensions (inches)										
	Shaft End													A	AA	AB	B	C	J	K1	K2	O	P	T
	D	2E	2F1	2F2	G	H	BA	ES	N-W	R	S	U												
SIE 324TS2	8	12.5	10.5	12	1.38	0.66	5.25	2.75	3.75	1.591	0.5	1.875	15.8	2	13	15	31.6	3.15	4.45	4.45	16.9	17.9	2.5	
SIE 324T	8	12.5	10.5	12	1.38	0.66	5.25	4.33	5.25	1.845	0.5	2.125	15.8	2	13	15	33.1	3.15	4.45	4.45	16.9	17.9	2.5	
SIE 326TS2	8	12.5	10.5	12	1.38	0.66	5.25	2.75	3.75	1.591	0.5	1.875	15.8	2	13	15	31.6	3.15	4.45	4.45	16.9	17.9	2.5	
SIE 326T	8	12.5	10.5	12	1.38	0.66	5.25	4.33	5.25	1.845	0.5	2.125	15.8	2	13	15	33.1	3.15	4.45	4.45	16.9	17.9	2.5	
SIE 364TS2	9	14	11.25	12.25	1.49	0.66	5.88	2.75	3.75	1.591	0.5	1.875	17.5	3	14.2	15	33.6	3.35	4.53	4.53	18.8	19.9	2.5	
SIE 364T	9	14	11.25	12.25	1.49	0.66	5.88	4.92	5.88	2.021	0.625	2.375	17.5	3	14.2	15	35.7	3.35	4.53	4.53	18.8	19.9	2.5	
SIE 365TS2	9	14	11.25	12.25	1.49	0.66	5.88	2.75	3.75	1.591	0.5	1.875	17.5	3	14.2	15	33.6	3.35	4.53	4.53	18.8	19.9	2.5	
SIE 365T	9	14	11.25	12.25	1.49	0.66	5.88	4.92	5.88	2.021	0.625	2.375	17.5	3	14.2	15	35.7	3.35	4.53	4.53	18.8	19.9	2.5	
SIE 404T	10	16	12.25	13.75	1.57	0.81	6.62	6.3	7.25	2.45	0.75	2.875	18.9	3	15.5	17.6	40.4	3.54	5.32	5.32	20.8	21.3	2.95	
SIE 405TS2	10	16	12.25	13.75	1.57	0.81	6.62	3.5	4.25	1.845	0.5	2.125	18.9	3	15.5	17.6	37.4	3.54	5.32	5.32	20.8	21.3	2.95	
SIE 405T	10	16	12.25	13.75	1.57	0.81	6.62	6.3	7.25	2.45	0.75	2.875	18.9	3	15.5	17.6	40.4	3.54	5.32	5.32	20.8	21.3	2.95	
SIE 444TS2	11	18	14.5	16.5	1.57	0.81	7.5	4.3	4.75	2.021	0.625	2.375	21.7	2x3	17.6	20.5	42	4.15	5.12	6.5	23.4	24.4	3.75	
SIE 444T	11	18	14.5	16.5	1.57	0.81	7.5	7.9	8.5	2.88	0.875	3.375	21.7	2x3	17.6	20.5	45.7	4.15	5.12	6.5	23.4	24.4	3.75	
SIE 445TS2	11	18	14.5	16.5	1.57	0.81	7.5	4.3	4.75	2.021	0.625	2.375	21.7	2x3	17.6	20.5	42	4.15	5.12	6.5	23.4	24.4	3.75	
SIE 445T	11	18	14.5	16.5	1.57	0.81	7.5	7.9	8.5	2.88	0.875	3.375	21.7	2x3	17.6	20.5	45.7	4.15	5.12	6.5	23.4	24.4	3.75	
SIE 447TS2	11	18	20	-	1.654	0.81	7.5	4.3	4.75	2.021	0.625	2.375	22.1	2x3	19.5	24	46.3	4.18	6.8	6.8	23.4	24.4	3.75	
SIE 447T4A	11	18	20	-	1.654	0.81	7.5	7.9	8.5	2.88	0.875	3.375	22.1	2x3	19.5	24	50	4.18	6.8	6.8	23.4	24.4	3.75	
SIE 447T4B	11	18	20	-	1.654	0.81	7.5	7.9	8.5	2.88	0.875	3.375	22.1	2x3	19.5	24	53.5	4.18	7.95	5.63	23.4	24.4	3.75	

Overall and Mounting Dimensions

C-Face with Rigid Base

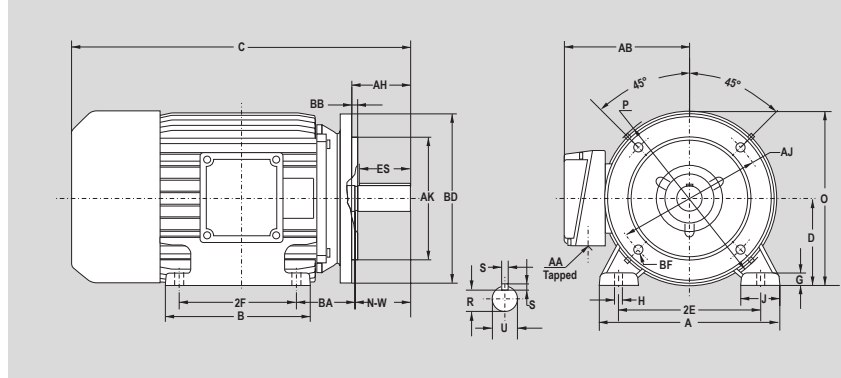

Motor Type	Mounting Dimensions (inches)														Overall Dimensions (inches)										
	Shaft End							C-Face																	
	D	2E	2F	G	H	BA	ES	N-W	R	S	U	AH	AJ	AK	BB	BF	A	AA	AB	B	BD	C	J	O	P
SIE 143TCL	3.50	5.50	4.00	0.39	0.34	2.25	1.52	2.25	0.771	0.188	0.875	2.12	5.88	4.5	0.16	3/8-16	6.62	3/4	6.50	5.83	6.50	14.20	1.66	7.48	8.27
SIE 145TCL	3.50	5.50	5.00	0.39	0.34	2.25	1.52	2.25	0.771	0.188	0.875	2.12	5.88	4.5	0.16	3/8-16	6.62	3/4	6.50	7.00	6.50	15.15	1.66	7.48	8.27
SIE 182TCL	4.50	7.50	4.50	0.60	0.41	2.75	1.94	2.75	0.986	0.250	1.125	2.62	7.25	8.5	0.25	1/2-13	9.00	1	7.90	8.31	8.90	17.70	2.13	9.09	9.53
SIE 184TCL	4.50	7.50	5.50	0.60	0.41	2.75	1.94	2.75	0.986	0.250	1.125	2.62	7.25	8.5	0.25	1/2-13	9.00	1	7.90	8.31	8.90	17.70	2.13	9.09	9.53
SIE 213TCL	5.25	8.50	5.50	0.67	0.41	3.50	2.55	3.38	1.201	0.312	1.375	3.13	7.25	8.5	0.25	1/2-13	10.24	1	8.92	8.70	8.90	22.25	2.20	10.96	11.61
SIE 215TCL	5.25	8.50	7.00	0.67	0.41	3.50	2.55	3.38	1.201	0.312	1.375	3.13	7.25	8.5	0.25	1/2-13	10.24	1	8.92	10.28	8.90	22.88	2.20	10.96	11.61
SIE 254TCL	6.25	10.00	8.25	0.58	0.55	4.25	3.11	4.00	1.416	0.375	1.625	3.75	7.25	8.5	0.25	1/2-13	12.28	1 1/4	10.08	9.92	10.00	25.83	2.36	13.18	14.17
SIE 256TCL	6.25	10.00	10.00	0.58	0.55	4.25	3.11	4.00	1.416	0.375	1.625	3.75	7.25	8.5	0.25	1/2-13	12.28	1 1/4	10.08	11.65	10.00	27.60	2.36	13.18	14.17
SIE 284TCL	7.00	11.00	9.50	0.89	0.55	4.75	3.53	4.62	1.591	0.500	1.875	4.38	9.00	10.5	0.25	1/2-13	13.78	1 1/2	10.34	13.11	11.25	31.16	2.75	14.01	14.17
SIE 284TSCL	7.00	11.00	9.50	0.89	0.55	4.75	2.10	3.25	1.416	0.375	1.625	3.00	9.00	10.5	0.25	1/2-13	13.78	1 1/2	10.34	13.11	11.25	27.20	2.75	14.01	14.17
SIE 286TCL	7.00	11.00	11.00	0.89	0.55	4.75	3.53	4.62	1.591	0.500	1.875	4.38	9.00	10.5	0.25	1/2-13	13.78	1 1/2	10.34	13.11	11.25	31.16	2.75	14.01	14.17
SIE 286TSCL	7.00	11.00	11.00	0.89	0.55	4.75	2.10	3.25	1.416	0.375	1.625	3.00	9.00	10.5	0.25	1/2-13	13.78	1 1/2	10.34	13.11	11.25	27.20	2.75	14.01	14.17

Overall and Mounting Dimensions

C-Face with Rigid Base

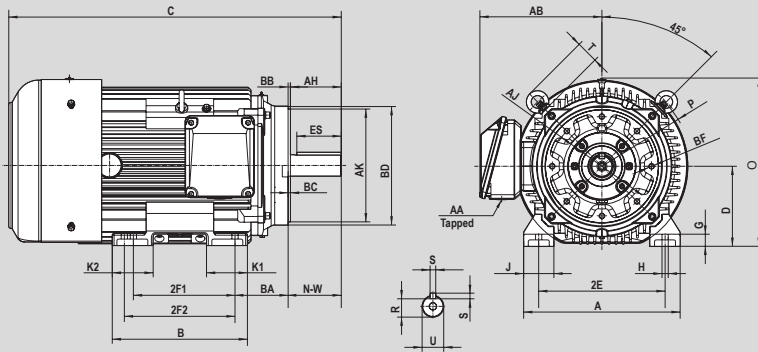

Mounting Dimensions (inches)

Overall Dimensions (inches)

Motor Type	Shaft End														C-Face															
	D	2E	2F1	2F2	G	H	BA	ES	N-W	R	S	U	AH	AJ	AK	BB/ BF		No.	A	AA	AB	B	BD	C	J	K1	K2	O	P	T
																size	size													
SIE 324TSCL2	8	12.5	10.50	12.00	1.38	0.66	5.25	2.75	3.75	1.591	0.5	1.875	3.50	11	12.5	0.25	5/8-11	4	15.8	2	13	15	13	31.6	3.15	4.45	4.45	16.9	17.9	2.5
SIE 324TCL	8	12.5	10.50	12.00	1.38	0.66	5.25	4.33	5.25	1.845	0.5	2.125	5.00	11	12.5	0.25	5/8-11	4	15.8	2	13	15	13	33.1	3.15	4.45	4.45	16.9	17.9	2.5
SIE 326TSCL2	8	12.5	10.50	12.00	1.38	0.66	5.25	2.75	3.75	1.591	0.5	1.875	3.50	11	12.5	0.25	5/8-11	4	15.8	2	13	15	13	31.6	3.15	4.45	4.45	16.9	17.9	2.5
SIE 326TCL	8	12.5	10.50	12.00	1.38	0.66	5.25	4.33	5.25	1.845	0.5	2.125	5.00	11	12.5	0.25	5/8-11	4	15.8	2	13	15	13	33.1	3.15	4.45	4.45	16.9	17.9	2.5
SIE 364TSCL2	9	14	11.25	12.25	1.49	0.66	5.88	2.75	3.75	1.591	0.5	1.875	3.50	11	12.5	0.25	5/8-11	8	17.5	3	14.2	15	13.2	33.6	3.35	4.53	4.53	18.8	19.9	2.5
SIE 364TCL	9	14	11.25	12.25	1.49	0.66	5.88	4.92	5.88	2.021	0.625	2.375	5.63	11	12.5	0.25	5/8-11	8	17.5	3	14.2	15	13.2	35.7	3.35	4.53	4.53	18.8	19.9	2.5
SIE 365TSCL2	9	14	11.25	12.25	1.49	0.66	5.88	2.75	3.75	1.591	0.5	1.875	3.50	11	12.5	0.25	5/8-11	8	17.5	3	14.2	15	13.2	33.6	3.35	4.53	4.53	18.8	19.9	2.5
SIE 365TCL	9	14	11.25	12.25	1.49	0.66	5.88	4.92	5.88	2.021	0.625	2.375	5.63	11	12.5	0.25	5/8-11	8	17.5	3	14.2	15	13.2	35.7	3.35	4.53	4.53	18.8	19.9	2.5
SIE 404TCL	10	16	12.25	13.75	1.57	0.81	6.62	6.30	7.25	2.450	0.75	2.875	7.00	11	12.5	0.25	5/8-11	8	18.9	3	15.5	17.6	13.2	40.4	3.55	5.32	5.32	20.8	21.3	2.95
SIE 405TSCL2	10	16	12.25	13.75	1.57	0.81	6.62	3.50	4.25	1.845	0.5	2.125	4.00	11	12.5	0.25	5/8-11	8	18.9	3	15.5	17.6	13.2	37.4	3.55	5.32	5.32	20.8	21.3	2.95
SIE 405TCL	10	16	12.25	13.75	1.57	0.81	6.62	6.30	7.25	2.450	0.75	2.875	7.00	11	12.5	0.25	5/8-11	8	18.9	3	15.5	17.6	13.2	40.4	3.55	5.32	5.32	20.8	21.3	2.95
SIE 444TSCL2	11	18	14.50	16.50	1.57	0.81	7.5	4.30	4.75	2.021	0.625	2.375	4.50	14	16	0.25	5/8-11	8	21.7	2x3	17.6	20.5	16.6	42.0	4.15	5.12	6.5	23.4	24.4	3.75
SIE 444TCL	11	18	14.50	16.50	1.57	0.81	7.5	7.90	8.50	2.880	0.875	3.375	8.25	14	16	0.25	5/8-11	8	21.7	2x3	17.6	20.5	16.6	45.7	4.15	5.12	6.5	23.4	24.4	3.75
SIE 445TSCL2	11	18	14.50	16.50	1.57	0.81	7.5	4.30	4.75	2.021	0.625	2.375	4.50	14	16	0.25	5/8-11	8	21.7	2x3	17.6	20.5	16.6	42.0	4.15	5.12	6.5	23.4	24.4	3.75
SIE 445TCL	11	18	14.50	16.50	1.57	0.81	7.5	7.90	8.50	2.880	0.875	3.375	8.25	14	16	0.25	5/8-11	8	21.7	2x3	17.6	20.5	16.6	45.7	4.15	5.12	6.5	23.4	24.4	3.75
SIE 447TSCL2	11	18	20.00	-	1.654	0.81	7.5	4.30	4.75	2.021	0.625	2.375	4.50	14	16	0.25	5/8-11	8	22.1	2x3	19.5	24	16.6	46.3	4.18	6.8	6.8	23.4	24.4	3.75
SIE 447TCL4A	11	18	20.00	-	1.654	0.81	7.5	7.90	8.50	2.880	0.875	3.375	8.25	14	16	0.25	5/8-11	8	22.1	2x3	19.5	24	16.6	50.0	4.18	6.8	6.8	23.4	24.4	3.75
SIE 447TCL4B	11	18	20.00	-	1.654	0.81	7.5	7.90	8.50	2.880	0.875	3.375	8.25	14	16	0.25	5/8-11	8	22.1	2x3	19.5	24	16.6	53.5	4.18	6.8	6.8	23.4	24.4	3.75

Overall and Mounting Dimensions

D-Flange with Rigid Base

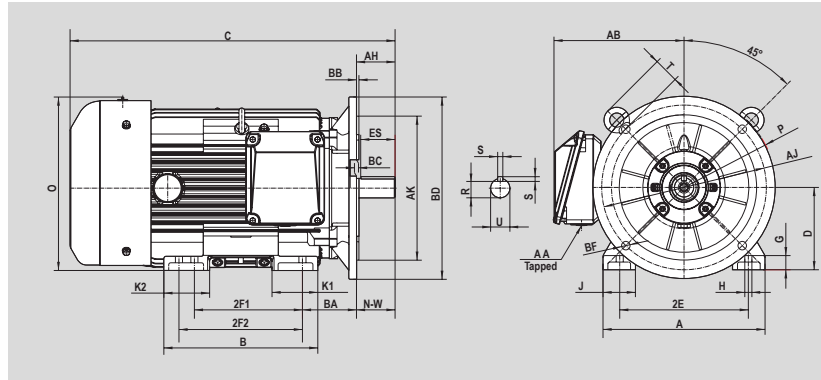

Motor Type	Mounting Dimensions (inches)																	Overall Dimensions (inches)												
	Shaft End										D-Flange																			
	D	2E	2F1	2F2	G	H	BA	ES	N-W	R	S	U	AH	AJ	AK	BB	BF	size No.	A	AA	AB	B	BD	C	J	K1	K2	O	P	T
SIE 324TSDL2	8	12.5	10.5	12	1.38	0.66	5.25	2.75	3.75	1.591	0.5	1.875	3.75	16	14	0.25	0.83	4	15.8	2	13	15	15.8	31.6	3.15	4.45	4.45	16.9	17.9	2.50
SIE 324TDL	8	12.5	10.5	12	1.38	0.66	5.25	4.33	5.25	1.845	0.5	2.125	5.25	16	14	0.25	0.83	4	15.8	2	13	15	15.8	33.1	3.15	4.45	4.45	16.9	17.9	2.50
SIE 326TSDL2	8	12.5	10.5	12	1.38	0.66	5.25	2.75	3.75	1.591	0.5	1.875	3.75	16	14	0.25	0.83	4	15.8	2	13	15	15.8	31.6	3.15	4.45	4.45	16.9	17.9	2.50
SIE 326TDL	8	12.5	10.5	12	1.38	0.66	5.25	4.33	5.25	1.845	0.5	2.125	5.25	16	14	0.25	0.83	4	15.8	2	13	15	15.8	33.1	3.15	4.45	4.45	16.9	17.9	2.50
SIE 364TSDL2	9	14	11.25	12.25	1.49	0.66	5.88	2.75	3.75	1.591	0.5	1.875	3.75	16	14	0.25	0.83	4	17.5	3	14.2	15	17.8	33.6	3.35	4.53	4.53	18.8	19.9	2.50
SIE 364TDL	9	14	11.25	12.25	1.49	0.66	5.88	4.92	5.88	2.021	0.625	2.375	5.88	16	14	0.25	0.83	4	17.5	3	14.2	15	17.8	35.7	3.35	4.53	4.53	18.8	19.9	2.50
SIE 365TSDL2	9	14	11.25	12.25	1.49	0.66	5.88	2.75	3.75	1.591	0.5	1.875	3.75	16	14	0.25	0.83	4	17.5	3	14.2	15	17.8	33.6	3.35	4.53	4.53	18.8	19.9	2.50
SIE 365TDL	9	14	11.25	12.25	1.49	0.66	5.88	4.92	5.88	2.021	0.625	2.375	5.88	16	14	0.25	0.83	4	17.5	3	14.2	15	17.8	35.7	3.35	4.53	4.53	18.8	19.9	2.50
SIE 404TDL	10	16	12.25	13.75	1.57	0.81	6.62	6.30	7.25	2.45	0.75	2.875	7.25	20	18	0.25	0.83	8	18.9	3	15.5	17.6	21.7	40.4	3.55	5.32	5.32	20.8	21.3	2.95
SIE 405TSDL2	10	16	12.25	13.75	1.57	0.81	6.62	3.50	4.25	1.845	0.5	2.125	4.25	20	18	0.25	0.83	8	18.9	3	15.5	17.6	21.7	37.4	3.55	5.32	5.32	20.8	21.3	2.95
SIE 405TDL	10	16	12.25	13.75	1.57	0.81	6.62	6.30	7.25	2.45	0.75	2.875	7.25	20	18	0.25	0.83	8	18.9	3	15.5	17.6	21.7	40.4	3.55	5.32	5.32	20.8	21.3	2.95
SIE 444TSDL2	11	18	14.5	16.5	1.57	0.81	7.50	4.30	4.75	2.021	0.625	2.375	4.75	20	18	0.25	0.83	8	21.7	2x3	17.6	20.5	21.7	42	4.15	5.12	6.5	23.4	24.4	3.75
SIE 444TDL	11	18	14.5	16.5	1.57	0.81	7.50	7.90	8.50	2.88	0.875	3.375	8.50	20	18	0.25	0.83	8	21.7	2x3	17.6	20.5	21.7	45.7	4.15	5.12	6.5	23.4	24.4	3.75
SIE 445TSDL2	11	18	14.5	16.5	1.57	0.81	7.50	4.30	4.75	2.021	0.625	2.375	4.75	20	18	0.25	0.83	8	21.7	2x3	17.6	20.5	21.7	42	4.15	5.12	6.5	23.4	24.4	3.75
SIE 445TDL	11	18	14.5	16.5	1.57	0.81	7.50	7.90	8.50	2.88	0.875	3.375	8.50	20	18	0.25	0.83	8	21.7	2x3	17.6	20.5	21.7	45.7	4.15	5.12	6.5	23.4	24.4	3.75
SIE 447TSDL2	11	18	20	-	1.654	0.81	7.50	4.30	4.75	2.021	0.625	2.375	4.75	20	18	0.25	0.83	8	22.1	2x3	19.5	24	21.7	46.3	4.18	6.8	6.8	23.4	24.4	3.75
SIE 447TDL4A	11	18	20	-	1.654	0.81	7.50	7.90	8.50	2.88	0.875	3.375	8.50	20	18	0.25	0.83	8	22.1	2x3	19.5	24	21.7	50	4.18	6.8	6.8	23.4	24.4	3.75
SIE 447TDL4B	11	18	20	-	1.654	0.81	7.50	7.90	8.50	2.88	0.875	3.375	8.50	20	18	0.25	0.83	8	22.1	2x3	19.5	24	21.7	53.5	4.18	6.8	6.8	23.4	24.4	3.75

Overall and Mounting Dimensions

JM/JP Pump Motors

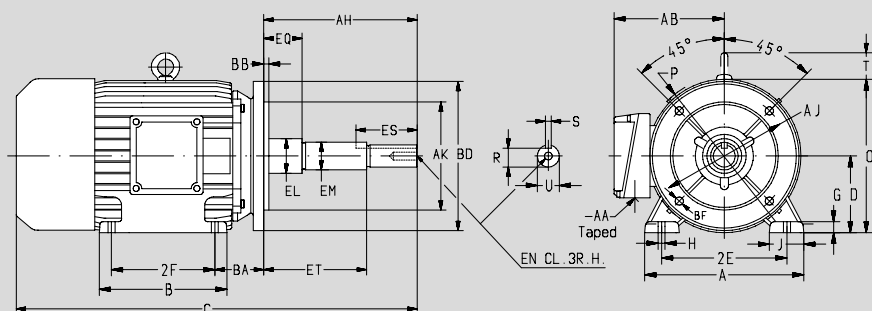

Frame	U	AH	AJ	AK	BB	BD Max	BF			EN			Keyseat			ET			
							Number	Tap size	Bolt Penetration Allowance	EL	EM	Tap size	Tap Drill Depth Max	Bolt Penetration Allowance	EQ		R	ES Min	S
143 JP	0.8745	7.343	5.875	4.500	0.156	6.50	4	3/8-16	0.56	1.156	1.0000	3/8-16	1.12	0.85	1.578	0.771	1.65	0.190	5.952
	0.8740	7.281		4.497	0.125					1.154	0.9995				1.548	0.756			
145 JP	0.8745	7.343	5.875	4.500	0.156	6.50	4	3/8-16	0.56	1.156	1.0000	3/8-16	1.12	0.85	1.578	0.771	1.65	0.190	5.952
	0.8740	7.281		4.497	0.125					1.154	0.9995				1.548	0.756			
182 JP	0.8745	7.343	5.875	4.500	0.156	6.50	4	3/8-16	0.56	1.250	1.0000	3/8-16	1.12	0.85	1.578	0.771	1.65	0.190	5.952
	0.8740	7.281		4.497	0.125					1.248	0.9995				1.548	0.756			
184 JP	0.8745	7.343	5.875	4.500	0.156	6.50	4	3/8-16	0.56	1.250	1.0000	3/8-16	1.12	0.85	1.578	0.771	1.65	0.190	5.952
	0.8740	7.281		4.497	0.125					1.248	0.9995				1.548	0.756			
143 JM	0.8745	4.281	5.875	4.500	0.156	6.50	4	3/8-16	0.56	1.156	1.0000	3/8-16	1.12	0.85	0.640	0.771	1.65	0.190	2.890
	0.8740	4.219		4.497	0.125					1.154	0.9995				0.610	0.756			
145 JM	0.8745	4.281	5.875	4.500	0.156	6.50	4	3/8-16	0.56	1.156	1.0000	3/8-16	1.12	0.85	0.640	0.771	1.65	0.190	2.890
	0.8740	4.219		4.497	0.125					1.154	0.9995				0.610	0.756			
182 JM	0.8745	4.281	5.875	4.500	0.156	6.50	4	3/8-16	0.56	1.250	1.0000	3/8-16	1.12	0.85	0.640	0.771	1.65	0.190	2.890
	0.8740	4.219		4.497	0.125					1.248	0.9995				0.610	0.756			
184 JM	0.8745	4.281	5.875	4.500	0.156	6.50	4	3/8-16	0.56	1.250	1.0000	3/8-16	1.12	0.85	0.640	0.771	1.65	0.190	2.890
	0.8740	4.219		4.497	0.125					1.248	0.9995				0.610	0.756			

Frame	D	2E	2F	G	H	BA	A	AA	AB	B	C	J	O	P	T
143 JP	3,50	5,50	4,00	0,39	0,34	2,36	6,62	3/4	6,50	5,83	18,183	1,66	7,48	8,27	-
145 JP	3,50	5,50	5,00	0,39	0,34	2,36	6,62	3/4	6,50	7,00	19,373	1,66	7,48	8,27	-
182 JP	4,50	7,50	4,50	0,60	0,41	2,78	9,00	1	7,90	8,31	21,353	2,13	9,09	9,53	1,77
184 JP	4,50	7,50	5,50	0,60	0,41	2,78	9,00	1	7,90	8,31	21,353	2,13	9,09	9,53	1,77
143 JM	3,50	5,50	4,00	0,39	0,34	2,36	6,62	3/4	6,50	5,83	15,125	1,66	7,48	8,27	-
145 JM	3,50	5,50	5,00	0,39	0,34	2,36	6,62	3/4	6,50	7,00	16,315	1,66	7,48	8,27	-
182 JM	4,50	7,50	4,50	0,60	0,41	2,78	9,00	1	7,90	8,31	18,291	2,13	9,09	9,53	1,77
184 JM	4,50	7,50	5,50	0,60	0,41	2,78	9,00	1	7,90	8,31	18,291	2,13	9,09	9,53	1,77

Overall and Mounting Dimensions

JM/JP Pump Motors

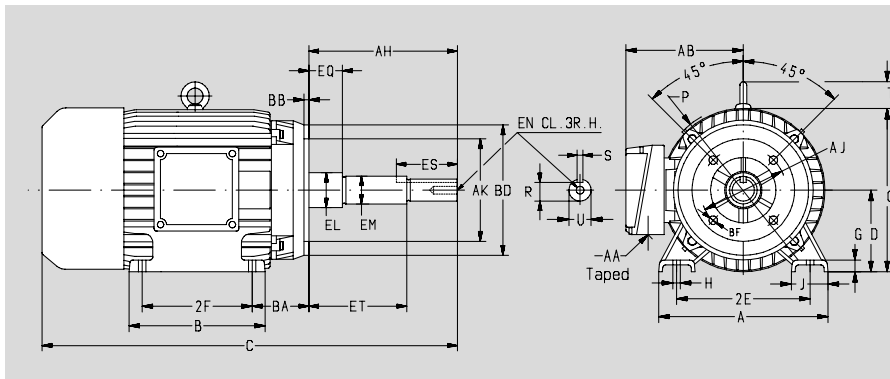

Frame	U	AH	AJ	AK	BB	BD Max	BF			EN			Keyseat						
							Number	Tap size	Bolt Penetration Allowance	EL	EM	Tap size	Tap Drill Depth Max	Bolt Penetration Allowance	EQ	R	ES Min	S	ET
213 JP	1.2495	8.156	7.250	8.500	0.312	9.00	4	3/8-16	0.85	1.750	1.3750	3/8-16	1.12	0.85	2.390	1.112	1.65	0.252	5.890
		8.094		8.497	0.250					1.748	1.3745				2.360	1.097		0.250	5.860
215 JP	1.2495	8.156	7.250	8.500	0.312	9.00	4	3/8-16	0.85	1.750	1.3750	3/8-16	1.12	0.85	2.390	1.112	1.65	0.252	5.890
		1.2490		8.094	8.497					0.250	1.748				1.3745	2.360		1.097	0.250
254 JP	1.2495	8.156	7.250	8.500	0.312	10.00	4	1/2-13	1.00	1.750	1.3750	1/2-13	1.50	1.00	2.390	1.112	2.53	0.252	5.890
		1.2490		8.094	8.497					0.250	1.748				1.3745	2.360		1.097	0.250
256 JP	1.2495	8.156	7.250	8.500	0.312	10.00	4	1/2-13	1.00	1.750	1.3750	1/2-13	1.50	1.00	2.390	1.112	2.53	0.252	5.890
		1.2490		8.094	8.497					0.250	1.748				1.3745	2.360		1.097	0.250
284 JP	1.2495	8.156	11.00	12.500	0.312	14.00	4	1/2-13	1.00	1.750	1.3750	1/2-13	1.50	1.00	2.390	1.112	2.53	0.252	5.890
		1.2490		8.094	12.495					0.250	1.748				1.3745	2.360		1.097	0.250
286 JP	1.2495	8.156	11.00	12.500	0.312	14.00	4	1/2-13	1.00	1.750	1.3750	1/2-13	1.50	1.00	2.390	1.112	2.53	0.252	5.890
		1.2490		8.094	12.495					0.250	1.748				1.3745	2.360		1.097	0.250
213 JM	0.8745	4.281	7.250	8.500	0.312	9.00	4	1/2-13	0.85	1.250	1.0000	3/8-16	1.12	0.85	0.640	0.771	1.65	0.190	2.890
		0.8740		4.219	8.497					0.250	1.248				0.9995	0.610		0.756	0.188
215 JM	0.8745	4.281	7.250	8.500	0.312	9.00	4	1/2-13	0.85	1.250	1.0000	3/8-16	1.12	0.85	0.640	0.771	1.65	0.190	2.890
		0.8740		4.219	8.497					0.250	1.248				0.9995	0.610		0.756	0.188
254 JM	1.2495	5.281	7.250	8.500	0.312	10.00	4	1/2-13	1.00	1.750	1.3750	1/2-13	1.50	1.00	0.640	1.112	2.53	0.252	3.015
		1.2490		5.219	8.497					0.250	1.748				1.3745	0.610		1.097	0.250
256 JM	1.2495	5.281	7.250	8.500	0.312	10.00	4	1/2-13	1.00	1.750	1.3750	1/2-13	1.50	1.00	0.640	1.112	2.53	0.252	3.015
		1.2490		5.219	8.497					0.250	1.748				1.3745	0.610		1.097	0.250
284 JM	1.2495	5.281	11.00	12.500	0.312	14.00	4	5/8-11	1.00	1.750	1.3750	1/2-13	1.50	1.00	0.645	1.112	2.53	0.252	3.020
		1.2490		5.219	12.495					0.250	1.748				1.3745	0.605		1.097	0.250
286 JM	1.2495	5.281	11.00	12.500	0.312	14.00	4	5/8-11	1.00	1.750	1.3750	1/2-13	1.50	1.00	0.645	1.112	2.53	0.252	3.020
		1.2490		5.219	12.495					0.250	1.748				1.3745	0.605		1.097	0.250

Frame	D	2E	2F	G	H	BA	A	AA	AB	B	C	J	O	P	T
213 JP	5,25	8,50	5,50	0,72	0,41	3,80	10,24	1	8,45	9,00	25,686	2,20	10,55	10,94	1,77
215 JP	5,25	8,50	7,00	0,72	0,41	3,80	10,24	1	8,45	9,60	25,686	2,20	10,55	10,94	1,77
254 JP	6,25	10,00	8,25	0,58	0,55	4,50	12,28	1 1/4	10,08	9,92	28,447	2,36	13,18	14,17	2,08
256 JP	6,25	10,00	10,00	0,58	0,55	4,50	12,28	1 1/4	10,08	11,65	30,176	2,36	13,18	14,17	2,08
284 JP	7,00	11,00	9,50	0,89	0,55	4,95	13,78	1 1/2	10,34	13,11	32,326	2,75	14,01	14,17	2,08
286 JP	7,00	11,00	11,00	0,89	0,55	4,95	13,78	1 1/2	10,34	13,11	32,326	2,75	14,01	14,17	2,08
213 JM	5,25	8,50	5,50	0,72	0,41	3,80	10,24	1	8,45	9,60	21,811	2,20	10,55	10,94	1,77
215 JM	5,25	8,50	7,00	0,72	0,41	3,80	10,24	1	8,45	9,60	21,811	2,20	10,55	10,94	1,77
254 JM	6,25	10,00	8,25	0,58	0,55	4,50	12,28	1 1/4	10,08	9,92	25,571	2,36	13,18	14,17	2,08
256 JM	6,25	10,00	10,00	0,58	0,55	4,50	12,28	1 1/4	10,08	11,65	27,301	2,36	13,18	14,17	2,08
284 JM	7,00	11,00	9,50	0,89	0,55	4,95	13,78	1 1/2	10,34	13,11	28,071	2,75	14,01	14,17	2,08
286 JM	7,00	11,00	11,00	0,89	0,55	4,95	13,78	1 1/2	10,34	13,11	28,071	2,75	14,01	14,17	2,08

Overall and Mounting Dimensions

JM/JP Pump Motors

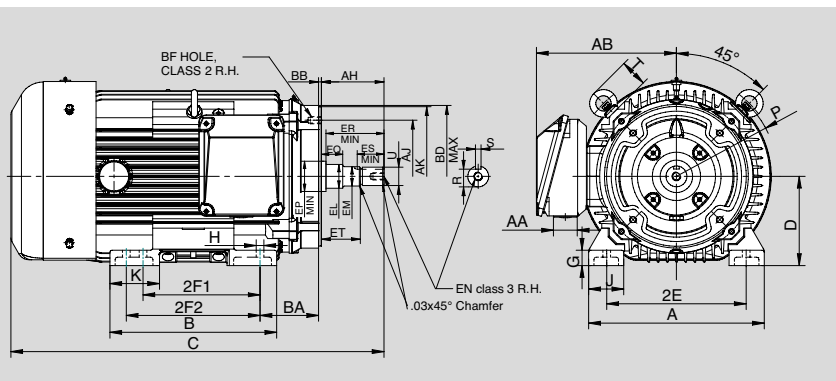

Frame	U	AH	AJ	AK	BB	BD Max	BF			EN				Keyseat			ET				
							Number	Tap size	Bolt Penetration Allowance	EL	EM	Tap size	Tap Drill Depth Max	Bolt Penetration Allowance	EP Min	EQ		ER Min	R	ES Min	S
324 JP	1.2495	8.156	11.0	12.500	0.312	14.0	4	5/8-11	0.94	1.750	1.3750	1/2-13	1.50	1.00	2.125	2.395	8.125	1.112-1.097	2.53	0.252-0.250	5.895
	1.2490	8.094		12.495	0.250					1.748	1.3745					2.355				5.855	
326 JP	1.2495	8.156	11.0	12.500	0.312	14.0	4	5/8-11	0.94	1.750	1.3750	1/2-13	1.50	1.00	2.125	2.395	8.125	1.112-1.097	2.53	0.252-0.250	5.895
	1.2490	8.094		12.495	0.250					1.748	1.3745					2.355				5.855	
364 JP	1.6245	8.156	11.0	12.500	0.312	14.0	4	5/8-11	0.94	2.125	1.7500	1/2-13	1.50	1.00	2.500	2.395	8.125	1.416-1.401	2.53	0.377-0.375	5.895
	1.6240	8.094		12.495	0.250					2.123	1.7495					2.355				5.855	
365 JP	1.6245	8.156	11.0	12.500	0.312	14.0	4	5/8-11	0.94	2.125	1.7500	1/2-13	1.50	1.00	2.500	2.395	8.125	1.416-1.401	2.53	0.377-0.375	5.895
	1.6240	8.094		12.495	0.250					2.123	1.7495					2.355				5.855	
324 JM	1.2495	5.281	11.0	12.500	0.312	14.0	4	5/8-11	0.94	1.750	1.3750	1/2-13	1.50	1.00	2.125	0.645	5.25	1.112-1.097	2.53	0.252-0.250	3.020
	1.2490	5.219		12.495	0.250					1.748	1.3745					0.605				2.980	
326 JM	1.2495	5.281	11.0	12.500	0.312	14.0	4	5/8-11	0.94	1.750	1.3750	1/2-13	1.50	1.00	2.125	0.645	5.25	1.112-1.097	2.53	0.252-0.250	3.020
	1.2490	5.219		12.495	0.250					1.748	1.3745					0.605				2.980	

Frame	D	2E	2F1	2F2	G	H	BA	A	AA	AB	B	C	J	K	O	P	T
324 JP	8	12.5	10.50	12.00	1.38	0.66	5.25	15.8	2	13.0	15.0	36.26	3.15	4.45	16.9	17.9	2.5
326 JP	8	12.5	10.50	12.00	1.38	0.66	5.25	15.8	2	13.0	15.0	36.26	3.15	4.45	16.9	17.9	2.5
364 JP	9	14.0	11.25	12.25	1.49	0.66	5.88	17.5	3	14.2	15.0	38.30	3.35	4.53	18.8	19.9	2.5
365 JP	9	14.0	11.25	12.25	1.49	0.66	5.88	17.5	3	14.2	15.0	38.30	3.35	4.53	18.8	19.9	2.5
324 JM	8	12.5	10.50	12.00	1.38	0.66	5.25	15.8	2	13.0	15.0	33.38	3.15	4.45	16.9	17.9	2.5
326 JM	8	12.5	10.50	12.00	1.38	0.66	5.25	15.8	2	13.0	15.0	33.38	3.15	4.45	16.9	17.9	2.5

List of Motor parts

Frame Size: 143÷286
 Motor series SIE

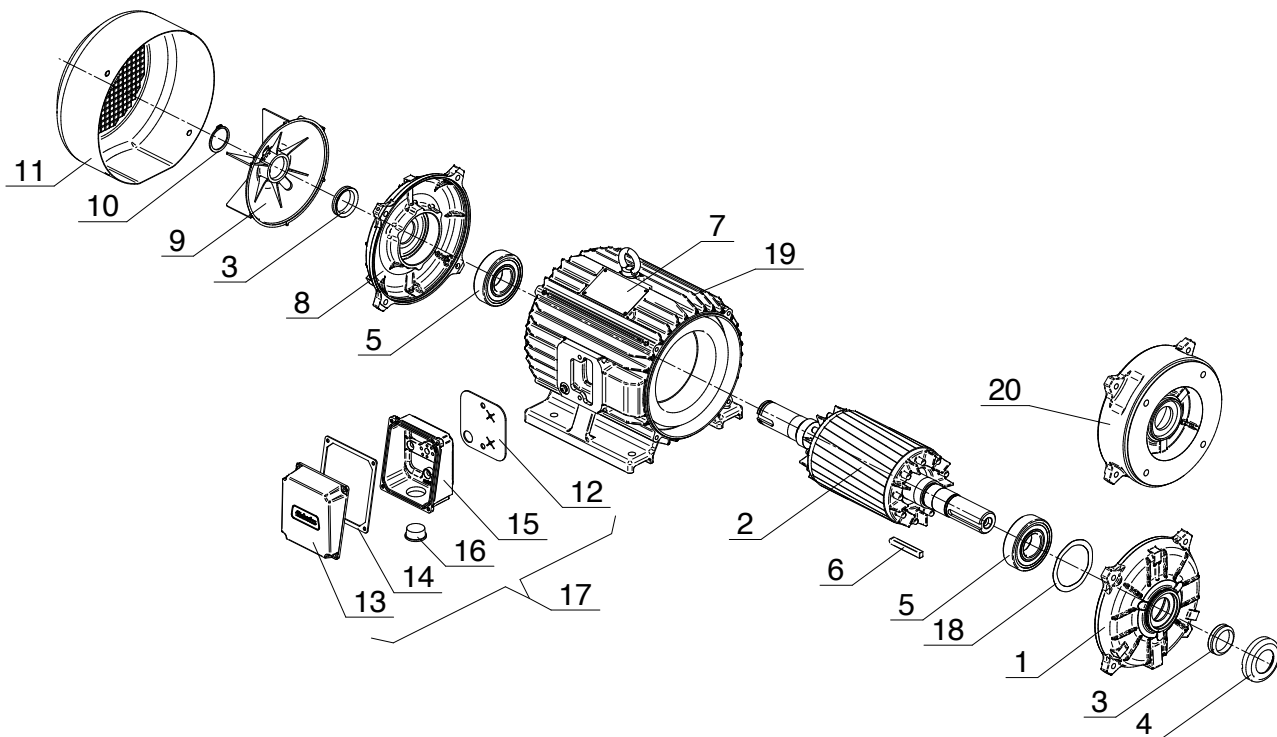

Item	Description
1	DE shield
2	rotor
3	shaft seal
4	shaft seal cover
5	bearing
6	key
7	name plate
8	NDE shield
9	fan
10	seeger ring
11	fan cover
12	rubber gasket
13	terminal box cover
14	rubber gasket
15	terminal box
16	plug
17	terminal box complete
18	spring washer
19	stator
20	flange C

DE – drive end
 NDE – non drive end

List of Motor parts

Frame Size: 320÷447
Motor series SIE

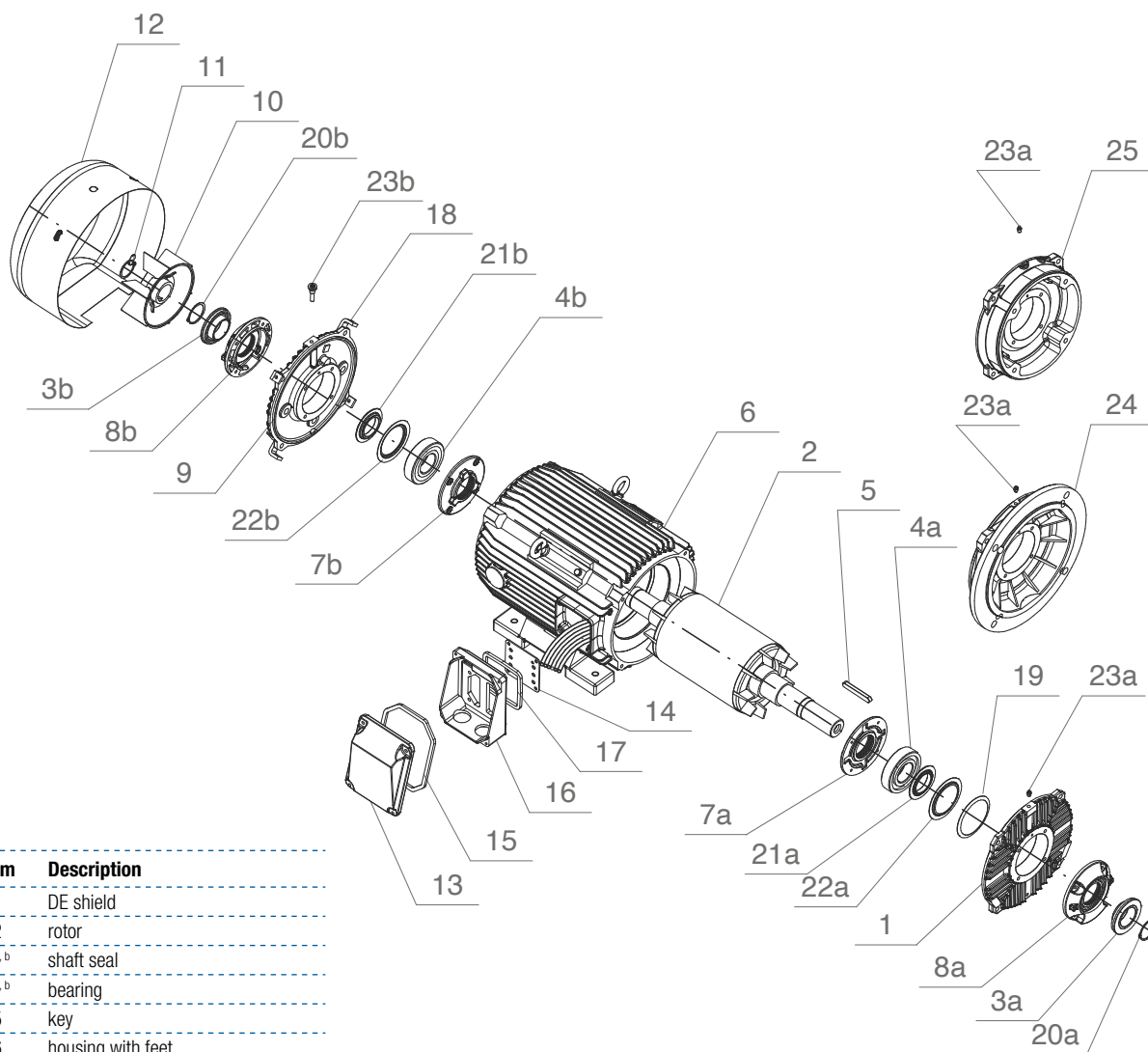

Item	Description
1	DE shield
2	rotor
3 ^{a, b}	shaft seal
4 ^{a, b}	bearing
5	key
6	housing with feet
7 ^{a, b}	internal bearing cap
8 ^{a, b}	external bearing cap
9	NDE shield
10	fan
11	seeger ring
12	fan cover
13	terminal box cover
14	rubber gasket
15	rubber gasket
16	terminal box housing
17	rubber gasket
18	fan cover support
19	spring washer
20 ^{a, b}	seeger ring
21 ^{a, b}	grease shield
22 ^{a, b}	bearing internal ring
23 ^{a, b}	grease nipple
24	flange „D”
25	flange „C”

DE – drive end
 NDE – non drive end

Ordering information

In order to select the proper motor and provide you the most accurate offer as the requirements of customer's applications are various, we ask you to specify below motor details:

Orders for motors should specify

- » motor type designation,
- » rated output,
- » rated speed,
- » operating duty,
- » supply voltage and connection,
- » frequency,
- » mounting arrangements, end shield material,
- » degree of protection,
- » type of driven machine,
- » other details regarding special requests,

and information concerning additional accessories e.g.

- » thermal protection,
- » anticondensation heaters,
- » vibration sensors,
- » etc.

When ordering special purpose motors one should also indicate:

- » required direction of rotation,
- » required degree of interior protection,
- » method of start-up,
- » method of coupling with the driven unit (gears, dimensions of belt pulleys, etc.),
- » type of driven machine (type of load), including the moment of inertia J or flywheel effect GD2 calculated to motor shaft,
- » other customer's specifications.

When ordering spare parts one should specify:

- » full designation of the motor type including its serial number (provided on the nameplate) or catalogue number,
- » degree of protection,
- » mounting arrangement,
- » name of part,
- » number of pieces.

As part of our development program, we reserve the right to alter or amend any of the specifications without giving prior notice.



Dear Customer,

Please complete the Order Form (included in the QR code on the left) and send it to motor@cantonigroup.com. In case you need assistance, do not hesitate to contact us at phone number: 0048 33 813 87 00. It will be our pleasure to help you.

Cantoni Motor Team

Download editable .pdf file from the website.

Cantoni Group - Certifications

Cantoni Group's factory, Celma Indukta was one of the first companies obtaining ISO 9001 certificate in Poland

All Cantoni Group manufacturing plants comply with the most important standards.

ISO 9001 is based on a number of quality management principles including a strong customer focus, the motivation and involvement of top management, the process approach and continuous improvement. Using ISO 9001 helps to ensure that customers get consistent, good quality products and services. Our aim is to produce high quality products certified according to the most important standards. We always focus our work to provide a product that meets the customer requirements, define the approach to continuous improvement and monitor

customer satisfaction. All employees in our Group are fully engaged and motivated to provide the top quality products. We achieve this thanks to skilled technicians, trained workers and customer oriented attitude.

As a demonstration of our aim to meet all high level international standard requirements, we are also certified ISO 14001 and OHSAS 18001 to prove our internal processes and behaviour.

ISO 14001 certification confirms that the organization manages their environmental responsibilities in an effective and internationally accepted way.

In Cantoni Group we know that taking care of the environment means taking care of our present and future.



With **OHSAS 18001** certificate, Cantoni Group confirms the necessity of controlling and improving health and safety aspects within the organization.

Employees are Cantoni Group's main asset, thus, their well-being and safety are our priority.

Our laboratory Celma Indukta is also **ISO 17025** certified by Canadian Standard Association (CSA) for two aspects: safety and energy efficiency verification requirements as independent unit.

The safety part – Supervised Manufacturers Testing Certification (SMTC) confirms that our laboratory is allowed for supervised manufactured safety certification program.

The energy efficiency part confirms that energy verification program for motors operating as SMTC can be performed according to CSA 390 standard at our facilities.

All our prototype motors are tested and approved before series production and samples of our final products are tested periodically to check compliance with all parameters defined. Our production range has also different types of products certifications based on specific technical requirements, like UL-CSA, GOST, EAC, ATEX, IEC Ex, CCC, Bureau Veritas, DNV-GL, etc.

Our technicians are constantly updated, informed and trained about every new regulation in order to provide all possible solutions to meet final customer requirements and also study and engineer ad-hoc products with customers developers.

Top quality electric motors

Cantoni Group's electric motors are manufactured in such a way as to provide a durable product that our customers can rely on:

- motors manufactured using high quality raw materials and components
- long-life bearings
- robust and tough construction
- raw materials only from European qualified suppliers
- production process from the beginning to the end at our facilities
- proven electrical performance

Our motors for many applications

Our motors are produced with the aim to be flexible and adaptable to many different applications. The long tradition and experience of our technical departments, supported by a flexible and strong organization, can assure an engineering of the motor series that meet the most common requirements and the more and more specific requests from the manufacturers of cutting-edge machines.

Our long collaboration with some of the most important players in the global industrial market has built a strong and stable organization that is able to support the customer in the development of the best solutions for its applications.

Cantoni Group continuous investments

The strategy of Cantoni Group is to realize a strong and continuous plan of investments with the aim to constantly increase the range of products, quality level and high productivity. Cantoni Group international market leadership has been created thanks to such open and future oriented attitude. Investments into the new professional machinery, equipment and infrastructure increase the quality control, capacity and save the environment.

The use of world class CNC, automatic and semi-automatic machinery guarantees precision, repeatability and accuracy. Such considerable development plan of Cantoni Group enhances the already wide range of production, maximizes the quality of offered products and has led to a growing number of innovations (new series for specific applications, new design and solutions) and international approvals.



Cantoni Group



Giampiero Cantoni, Founder of Cantoni Group

Since almost a century, the Cantoni Group has been known worldwide as a leader in manufacturing and supplying electric motors, components and tools.

Thanks to the entrepreneurial commitment and great talent, the founder of the Group, **Prof. Giampiero Cantoni**, created diversified Group Enterprise that has gained outstanding success on the Domestic and International markets, placing us among the most important European manufacturers.

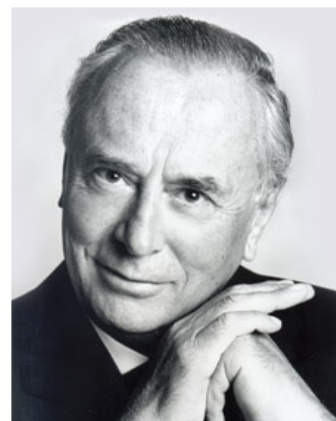

Cantoni Motor



Cantoni Motor, the International Sales Office and Headquarters, coordinates the sales and purchasing for the whole Cantoni Group.

The history of Cantoni Motor goes back to 1945 when Elektrim Export Office in Poland was created. Through the next years, many internal changes had occurred, the Office changed its name to Elektrim Motor, to become finally in the year 2000 – Cantoni Motor S.A. – a company with Italian ownership.

Cantoni Motor provides complete customer service, from offer submission until shipment, after-sales and full technical support. Thanks to the flexible organization, our technical and sales team

is able to face all requirements of modern market and realize the most challenging projects.

As the Headquarters, the company not only coordinates the sales and purchasing of key materials for the production of electric motors in the Group, but also is responsible for marketing and promotion actions as well as for certification processes, trademarks and patents.

Cantoni Group produces and exports high quality industrial electric motors – from 0,04 kW up to 6000 kW, in standard and special executions. Our motors are tough and reliable and operate in almost all industrial segments from pumps, fans, compressors, conveyors, mining, processing to power plants, etc.



From the project to the application



Driving Your Business

