

CANTONI
MOTOR

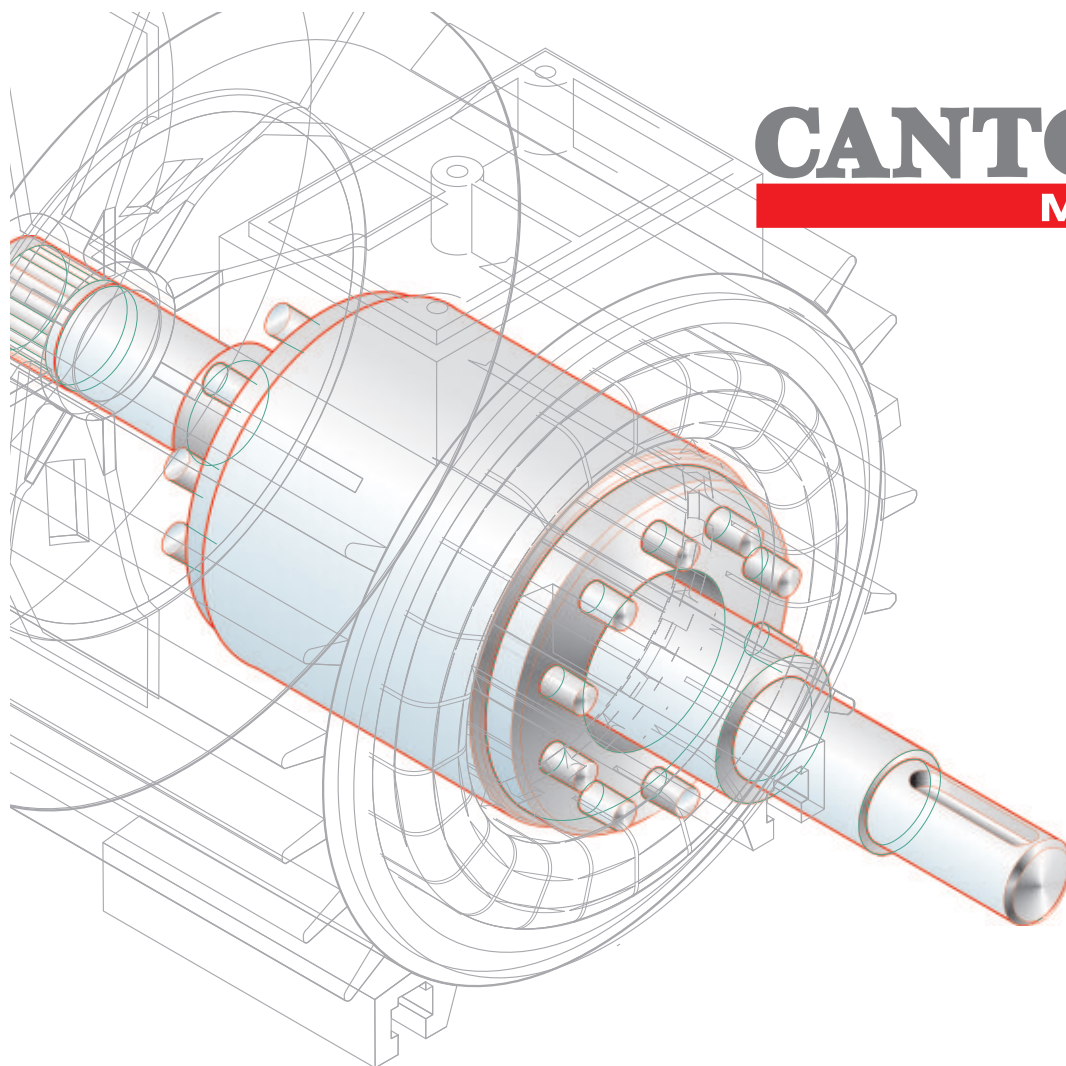

**General
Purpose
Slip-Ring
Induction
Motors**

CE



ISO 9001



Product Catalogue



Cantoni Motor S.A.
M. Grażyńskiego 22, 43-300 Bielsko-Biała, Poland
tel.: +48 33 813 87 00
fax: +48 33 813 87 01
motor@cantonigroup.com
www.cantonimotor.com



since 1950



since 1878



since 1954



since 1920



since 1921

The catalogue covers slip-ring induction motors called also wound rotor induction motors that are applied to start a high inertia load or a load that requires a very high starting torque across the full speed range. These motors can be also applied in drives where limited speed regulation is required.

Our motors are designed for long life and reliable operation.

FEATURES AND BENEFITS

The slip-ring motor is an induction machine where the rotor comprises a set of coils that are terminated in slip rings to which external resistance can be connected. The stator is the same as is used with a standard squirrel cage motor.

By changing the resistance connected to the rotor circuit, the speed/current and speed/torque curves can be altered.

By correctly selecting the resistors used in the secondary

resistance or slip ring starter, the motor is able to produce maximum torque at a relatively low current from zero speed to full speed. A secondary use of the slip ring motor, is to provide a means of speed control. Because the torque curve of the motor is effectively modified by the resistance connected to the rotor circuit, the speed of the motor can be altered. Increasing the value of resistance on the rotor circuit will move the speed of maximum torque down.

	Frame size	Poles	DE Bearing	NDE Bearing	Degree of Protection	Cooling System	Insulation Class Stator / Rotor
	SUg 200	4-8	6212 C3	6212 C3	IP 54 (55)	IC 411	F/F
	SUg 225	4-8	6213 C3	6213 C3	IP 54 (55)	IC 411	F/F
	SUg 250	4-8	6215 C3	6215 C3	IP 54 (55)	IC 411	F/F
	SUg 280	4-8	6217 C3	6217 C3	IP 54 (55)	IC 411	F/F
	SUg 315	4	NU 320 EM1	6320 MC3	IP 54 (55)	IC 411	F/F
	SUg 315	6-8	NU 320 EM1	6320 C3	IP 54 (55)	IC 411	F/F
	SCUe 315	4	NU 320 EM1	6320 MC3	IP 23	IC 01	F/F
	SCUe 315	6-8	NU 320 EM1	6320 C3	IP 23	IC 01	F/F
	SUg 355	4	NU 322 EM1	6322 MC3	IP 54 (55)	IC 411	F/F
	SUg 355	6-12	NU 322 EM1	6322 C3	IP 54 (55)	IC 411	F/F
	SCUe 355	4	NU 322 EM1	6322 MC3	IP 23	IC 01	F/F
	SCUe 355	6-12	NU 322 EM1	6322 C3	IP 23	IC 01	F/F
	SCUe 400	6-12	NU 324 EM1	6322 C3	IP 23	IC 01	F/F
	SUem 400	6-12	NU 324 EM1	6322 C3	IP 44	IC 611	F/F



ISO 9001

IEC

ORDERING INFORMATION

When placing an order, the following motor data should be given:

- Motor type designation
- Rated output
- Rated speed
- Supply voltages
- Frequency
- Mounting arrangements
- Degree of protection
- Special requirements

Information concerning additional accessories e.g.

- Thermal protection
- Anticondensation heaters
- Vibration sensors, etc.

As part of our development program, we reserve the right to alter or amend any of the specifications included in this catalog without giving prior notice.

Totally Enclosed Motors IP 54 (IP 55)
Insulation Class F

TECHNICAL DATA

Type of Motor	Rated Output		Rated Speed	Full Load Current		Efficiency	Power Factor	Rated Torque	Breakdown Torque	Voltage of Rotor	Current of Rotor	Resistance of Rotor	Specific Resistance	Moment of Inertia	Weight (IMB3)
	P _N			I _N at rated voltage											
	[kW]	[HP]		[min ⁻¹]	[A] _{400V}										
2p=4 n_s=1500 rpm															
SUg 200 L4A	18,5	25	1455	34,2	-	89,6	0,87	122	3,8	215	54,5	0,0473	2,2786	0,35	275
SUg 200 L4B	22	30	1455	39,4	-	90,2	0,89	145	3,6	253	55	0,0553	2,6555	0,41	285
SUg 225 M4	30	40	1460	54,2	-	91	0,88	197	3,8	305	62,5	0,0503	2,8175	0,54	365
SUg 250 MA	37	50	1455	67,5	-	89,5	0,88	243	4,3	200	117	0,0195	0,9869	0,95	485
SUg 250 M4B	45	60	1460	81,7	-	90,3	0,88	295	4,3	240	118	0,0208	1,1743	0,97	510
SUg 280 S4	55	75	1455	96	-	91	0,91	362	3,3	240	144	0,0171	0,9623	1,65	620
SUg 280 M4	75	100	1472	132,1	-	93	0,88	487	4,2	340	139	0,0185	1,4122	1,95	700
SUg 315 S4A	90	125	1461	-	171	90,7	0,88	588	3,2	215	258	0,0062	0,4811	3,5	1020
SUg 315 S4B	110	150	1468	-	207	91,9	0,88	716	3,5	271	248	0,0069	0,6309	4,1	1100
SUg 315 M4	132	175	1472	-	243	92,8	0,885	856	3,8	327	245	0,0075	0,7706	4,7	1210
SUg 355 S4	160	220	1477	-	294	92,8	0,89	1035	3,4	342	284	0,0064	0,6953	6,8	1610
SUg 355 M4	200	270	1481	-	360	93,8	0,9	1290	3,8	437	176	0,0072	1,4335	8,1	1810
SUg 355 L4	250	340	1484	-	450	94,9	0,89	1609	4,4	506	298	0,0063	0,9803	13	1960
2p=6 n_s=1000 rpm															
SUg 200 L6	15	20	965	28,5	-	87,7	0,87	149	3,1	215	44,5	0,0611	2,7894	0,51	280
SUg 225 M6A	18,5	25	975	34,4	-	90,3	0,86	182	3,2	220	53,5	0,0441	2,3742	0,64	355
SUg 225 M6B	22	30	972	40,9	-	90,3	0,86	217	3,1	247	56,5	0,0459	2,524	0,72	370
SUg 250 M6A	30	40	972	57,0	-	89,5	0,85	295	3,4	150	126	0,0113	0,6873	1,35	485
SUg 250 M6B	37	50	975	74,1	-	90,5	0,8	345	3,6	182	128	0,0124	0,8209	1,5	525
SUg 280 S6	45	60	977	84,5	-	91,7	0,84	441	3,3	196	144	0,0124	0,7858	1,65	660
SUg 280 M6	55	75	975	105,5	-	91,8	0,82	540	3,5	230	151	0,0127	0,8794	2,22	690
SUg 315 S6	75	100	973	-	143	91,6	0,86	736	3,3	268	170	0,0138	0,9102	4,8	1000
SUg 315 M6A	90	125	976	-	170	92,4	0,87	881	3,5	324	168	0,015	1,1135	5,4	1100
SUg 315 M6B	110	150	980	-	211	93,1	0,85	1072	4	406	162	0,0164	1,4469	6,2	1180
SUg 355 S6	132	175	981	-	247	93,4	0,87	1285	3,2	374	213	0,0123	1,0138	8,2	1540
SUg 355 M6	160	220	985	-	300	94,3	0,86	1551	3,8	490	195	0,014	1,4508	10,4	1740
SUg 355 L6	200	270	986	-	369	94,8	0,87	1937	4,1	615	194	0,0143	1,8303	17	1950
2p=8 n_s=750 rpm															
SUg 200 L8	11	15	717	23,8	-	86,3	0,77	147	2,6	225	31	0,1087	4,1904	0,51	280
SUg 225 M8A	15	20	725	33,3	-	87,5	0,74	198	3	190	50	0,0475	2,1939	0,64	350
SUg 225 M8B	18,5	25	725	37,1	-	89,3	0,8	244	2,7	220	53,5	0,0533	2,3742	0,8	375
SUg 250 M8A	22	30	730	47	-	89	0,76	288	2,9	135	103	0,0439	0,7567	1,35	500
SUg 250 M8B	30	40	732	65,6	-	89,3	0,74	392	3,1	180	105	0,0489	0,9897	1,6	535
Sug 280 S8	37	50	730	77,2	-	91	0,76	485	2,9	175	133	0,0445	0,7597	1,64	655
SUg 280 M8	47	63	728	94	-	91,5	0,79	618	2,6	217	137	0,0506	0,9145	2,02	735
SUg 315 S8	55	75	731	-	115	91,2	0,8	719	3,4	250	134	0,0146	1,0771	5,2	1095
SUg 315 M8A	75	100	731	-	152	91,7	0,82	980	3,1	281	156	0,0156	1,04	5,6	1150
SUg 315 M8B	90	125	733	-	183	92,4	0,81	1173	3,3	351	155	0,0171	1,3074	6,4	1200
SUg 355 S8	110	150	735	-	218	93,4	0,82	1429	2,9	350	188	0,0114	1,0749	10,9	1570
SUg 355 M8A	132	175	735	-	261	93,8	0,82	1715	3,1	413	191	0,0136	1,2486	12,4	1690
SUg 355 M8B	160	220	737	-	313	94,6	0,82	2073	3,2	504	189	0,0188	1,5396	14,8	1880
2p=10 n_s=600 rpm															
SUg 355 S10A	75	100	584	-	161	92,1	0,77	1226	2,6	270	168	0,0154	0,9279	9,1	1490
SUg 355 S10B	90	125	585	-	189	92,6	0,78	1469	2,6	330	165	0,0179	1,1547	11,2	1650
SUg 355 M10A	110	150	586	-	227	93,2	0,79	1793	2,5	400	165	0,0207	1,3996	13,5	1870
SUg 355 M10B	132	175	588	-	275	93,5	0,78	2144	2,7	476	166	0,0223	1,6555	15	1980
2p=12 n_s=500 rpm															
SUg 355 S12	75	100	485	-	168	91,6	0,74	1477	1,8	176	260	0,0071	0,3908	11,6	1650
SUg 355 M12A	90	125	486	-	198	92,3	0,75	1769	1,8	215	255	0,0082	0,4868	13,9	1870
SUg 355 M12B	105	140	487	-	232	92,8	0,74	2059	1,9	252	252	0,0089	0,5774	15,4	1980

Specific resistance k:

If connected to rotor winding the starting torque of motor is equal to the rated torque.

$$k = \frac{\sqrt{3} \times U_2}{3 \times I_2} [\Omega]$$

where: U₂ - rotor voltage [V]
I₂ - rotor current [A]

Totally Enclosed Motors IP 44
Insulation Class F

Type of Motor	Rated Output		Rated Speed	Full Load Current at 380 V	Efficiency	Power Factor	Rated Torque	Breakdown Torque	Voltage of Rotor	Current of Rotor	Resistance of Rotor	Specific Resistance	Moment of Inertia	Weight (IMB3)
	P _N [kW]	[HP]												
2p=6 n_s=1000 rpm														
SUem 400 S6B	250	340	982	480	94	0,84	2431	3,5	540	276	0,0118	1,1296	19	2050
SUem 400 M6	315	430	983	592	94,4	0,84	3060	3	620	310	0,0131	1,1547	22	2150
2p=8 n_s=750 rpm														
SUem 400 M8A	200	270	737	408	93	0,8	2592	2,9	500	239	0,0133	1,2078	22	2100
SUem 400 M8B	235	315	738	460	93,5	0,83	3041	2,8	582	240	0,015	1,4001	25,6	2250
2p=10 n_s=600 rpm														
SUem 400 M10A	132	175	586	281	92,7	0,77	2151	2,9	367	224	0,0134	0,9459	22,6	2040
SUem 400 M10B	160	220	588	339	93,2	0,77	2599	2,9	448	220	0,0148	1,1757	25,8	2170
SUem 400 M10C	200	270	588	416	93,6	0,78	3248	2,9	538	228	0,0167	1,3623	30,1	2350
2p=12 n_s=500 rpm														
SUem 400 S12B	110	150	480	235	91,2	0,78	2189	2	278	241	0,0139	0,666	22	2020
SUem 400 M12A	125	170	484	264	92,4	0,78	2466	2,1	278	237	0,0153	0,6772	24,7	2170
SUem 400 M12B	145	195	486	304	92,8	0,78	2849	2,5	395	221	0,0173	1,0319	29,9	2300

TECHNICAL DATA

Specific resistance k:
 If connected to rotor winding the starting torque of motor is equal to the rated torque.

$$k = \frac{\sqrt{3} \times U_2}{3 \times I_2} \text{ [}\Omega\text{]}$$

where: U₂ - rotor voltage [V]
 I₂ - rotor current [A]

Open Drip-Proof Motors IP 23
Insulation Class F

TECHNICAL DATA

Type of Motor	Rated Output		Rated Speed	Full Load Current at 380 V	Efficiency	Power Factor	Rated Torque	Breakdown Torque	Voltage of Rotor	Current of Rotor	Resistance of Rotor	Specific Resistance	Moment of Inertia	Weight (IMB3)
	P _N [kW]	P _N [HP]												
	n _N [min ⁻¹]	I _N [A] _{380V}	η _N [%]	cos φ _N [-]	T _N [Nm]	T _b /T _N [-]	U ₂ [V]	I ₂ [A]	R ₂ [Ω]	k [Ω]	J [kgm ²]	m [kg]		
2p=4 n_s=1500 rpm														
SCUe 315 S4	160	220	1463	298	92,5	0,88	1045	2,2	243	397	0,00574	0,3534	3,62	970
SCUe 315 M4	200	270	1465	370	93,3	0,88	1304	2,2	286	417	0,00614	0,396	4	1040
SCUe 355 S4	250	340	1459	459	93	0,89	1637	2,7	336	448	0,008	0,433	5,85	1250
SCUe 355 M4	315	430	1462	574	93,7	0,89	2059	2,8	400	472	0,00858	0,4893	6,48	1350
2p=6 n_s=1000 rpm														
SCUe 315 S6	110	150	969	212	91,5	0,86	1085	2,1	157	427	0,0039	0,2123	4,82	940
SCUe 315 M6	132	175	973	250	92,5	0,86	1296	2,2	190	421	0,00426	0,2606	5,38	1040
SCUe 355 S6	160	220	970	300	92,1	0,88	1576	2,7	342	283	0,0145	0,6977	8,25	1200
SCUe 355 M6	200	270	971	373	92,6	0,88	1968	2,8	400	302	0,0155	0,7647	9	1300
SCUe 400 S6A	250	340	976	473	93,3	0,86	2447	2,7	450	343	0,0114	0,7575	14	1600
SCUe 400 S6B	315	430	978	585	94	0,87	3078	2,8	555	350	0,0118	0,9155	17	1760
2p=8 n_s=750 rpm														
SCUe 315 S8	90	125	725	182	91,5	0,82	1186	2,1	242	225	0,0138	0,621	4,85	940
SCUe 315 M8	110	150	726	221	92	0,82	1448	2,2	282	234	0,0148	0,6958	5,38	1000
SCUe 355 S8	132	175	719	262	91	0,84	1754	2,3	285	282	0,0168	0,5835	9,26	1170
SCUe 355 M8	160	220	722	315	91,8	0,84	2117	2,5	344	282	0,0182	0,7043	10,4	1250
SCUe 400 S8B	200	270	731	392	92,3	0,84	2614	2,2	405	296	0,0123	0,79	19,3	1630
SCUe 400 M8A	250	340	733	492	93	0,83	3259	2,3	495	303	0,0133	0,9432	21,7	1800
SCUe 400 M8B	315	430	735	609	93,5	0,84	4095	2,25	575	326	0,015	1,0183	25,3	1990
2p=10 n_s=600 rpm														
SCUe 315 S10	55	75	579	116	90,8	0,79	908	2,3	212	158	0,00747	0,7747	5,3	910
SCUe 315 M10	75	100	580	158	91,3	0,79	1236	2,2	254	180	0,00808	0,8147	5,9	980
SCUe 355 S10	90	125	577	190	90,9	0,79	1490	1,8	240	240	0,00618	0,5774	9,83	1180
SCUe 355 M10A	110	150	577	232	91,2	0,79	1822	1,8	275	250	0,00655	0,6351	10,8	1250
SCUe 355 M10B	132	175	581	261	91	0,8	2171	2	279	283	0,0164	0,5692	11,5	1300
SCUe 400 M10A	160	220	583	333	92,3	0,79	2622	2,4	367	275	0,0134	0,7705	22,3	1740
SCUe 400 M10B	200	270	585	414	92,8	0,79	3267	2,4	448	280	0,00634	0,9238	25,5	1870
SCUe 400 M10C	250	340	585	509	93,3	0,8	4083	2,4	538	290	0,00714	1,0711	29,8	2050
2p=12 n_s=500 rpm														
SCUe 355 S12	75	100	478	170	89,3	0,75	1499	1,6	133	347	0,00602	0,2213	10,1	1220
SCUe 355 M12	90	125	479	203	89,8	0,75	1795	1,6	154	359	0,0066	0,2477	11,3	1280
SCUe 400 S12A	110	150	476	244	90	0,76	2208	1,9	216	311	0,0136	0,401	18,6	1600
SCUe 400 S12B	132	175	480	279	90,8	0,79	2628	1,7	272	296	0,0143	0,5305	21,7	1720
SCUe 400 M12A	160	220	482	334	92,1	0,79	3172	1,7	315	309	0,0164	0,5886	24,4	1870
SCUe 400 M12B	200	270	483	417	92,3	0,79	3957	1,8	389	309	0,0173	0,7268	28,6	2050

Specific resistance k:

If connected to rotor winding the starting torque of motor is equal to the rated torque.

$$k = \frac{\sqrt{3} \times U_2}{3 \times I_2} [\Omega]$$

where: U₂ - rotor voltage [V]
I₂ - rotor current [A]

**FOOT MOUNTED MOTORS - IM B3
IP 54 (IP 55)**

SUg 200 to 280

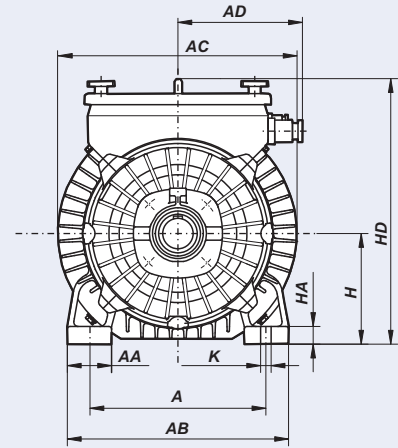
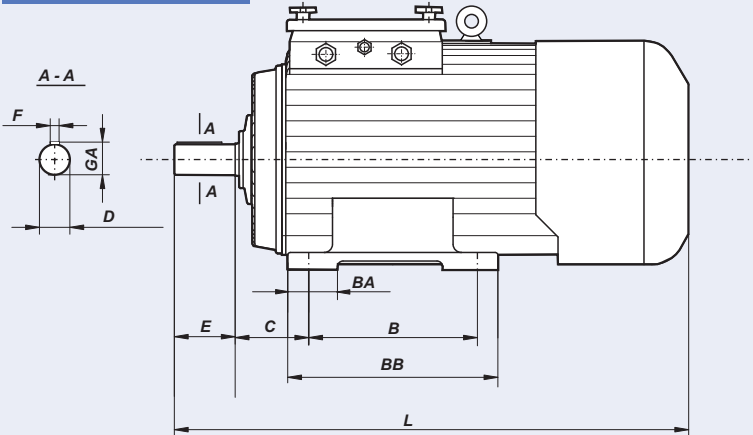

SUg 315 to 355

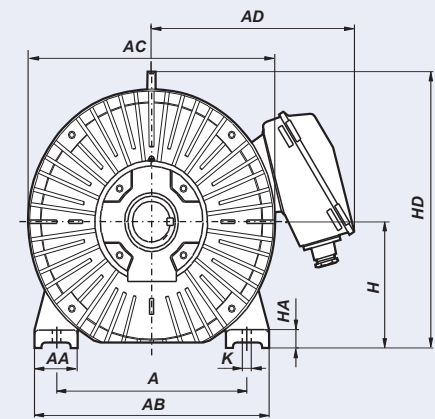
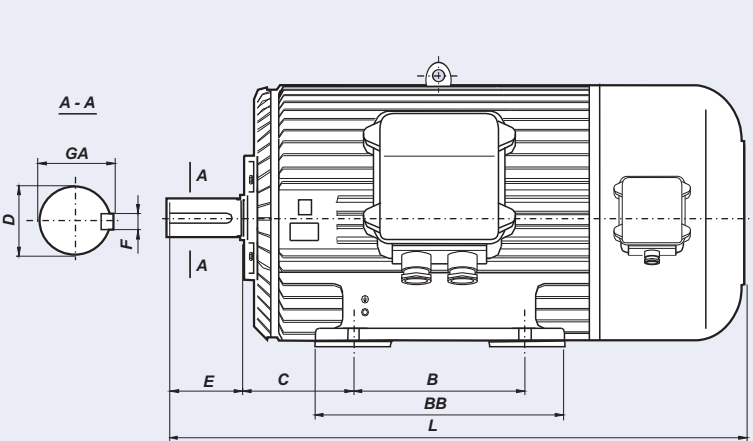

Type	A	B	C	D	E	F	GA	H	HA	K	AA	AB	AC	AD	BA	BB	HD	L
SUg 200 L	318	305	133	55m6	110	16h9	59	200	32	19	80	400	450	225	90	380	480	930
SUg 225 M	356	311	149	60m6	140	18h9	64	225	35	19	85	445	505	240	110	400	540	1030
SUg 250 M	406	349	168	70m6	140	20h9	74,5	250	36	24	90	495	545	280	120	420	590	1190
SUg 280 S	457	368	190	80m6	170	22h9	85	280	40	24	100	560	610	305	120	470	675	1240
SUg 280 M	457	419	190	80m6	170	22h9	85	280	40	24	100	560	610	305	120	520	675	1290
SUg 315 S.	508	406	216	80m6	170	22h9	85	315	45	28	134	640	694	585	150	500	750	1402
SUg 315 M.	508	457	216	80m6	170	22h9	85	315	45	28	134	640	694	585	150	550	750	1453
SUg 355 S	610	500	254	100m6	210	28h9	106	355	50	28	158	720	764	620	170	600	848	1607
SUg 355 M	610	560	254	100m6	210	28h9	106	355	50	28	158	720	764	620	205	730	848	1667
SUg 355 L	610	630	254	100m6	210	28h9	106	355	50	28	158	720	764	620	205	730	848	1737

DIMENSION DRAWINGS

FOOT/FLANGE MOUNTED MOTORS - IM B35
FLANGE MOUNTED MOTORS - IM B5
IP 54 (IP 55)

SULg 200 to 280

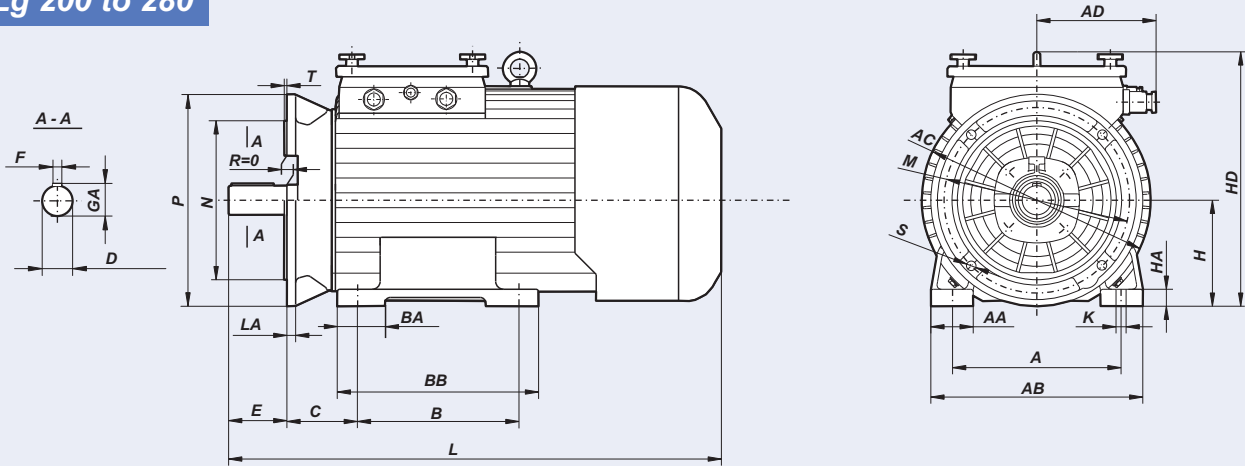

Motor type	A	B	C	D	E	F	GA	H	HA	K	AA	AB	AC	AD	BA	BB	HD	L	LA	M	N	P	T	S	Φ	holes
SULg 200 L	318	305	133	55m6	110	16h9	59	200	32	19	80	400	450	225	90	380	480	930	16,5	350	300j6	400	5	18	4	
SULg 225 M	356	311	149	60m6	140	18h9	64	225	35	19	85	445	505	240	110	400	540	1030	18	400	350j6	450	5	18	8	
SULg 250 M	406	349	168	70m6	140	20h9	74,5	250	36	24	90	495	545	280	120	420	590	1190	19	500	450j6	550	5	18	8	
SULg 280 S	457	368	190	80m6	170	22h9	85	280	40	24	100	560	610	305	120	470	675	1240	20	500	450j6	550	5	18	8	
SULg 280 M	457	419	190	80m6	170	22h9	85	280	40	24	100	560	610	305	120	520	675	1290	20	500	450j6	550	5	18	8	

SUKg 200 to 280

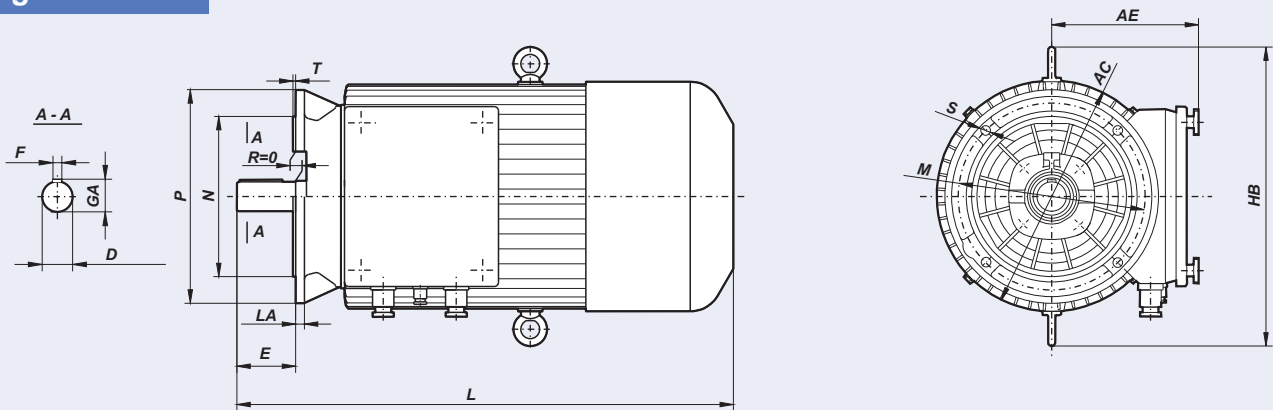

Motor type	D	E	F	GA	AC	AE	HB	L	LA	M	N	P	T	S	Φ	holes
SUKg 200 L	55m6	110	16h9	59	450	275	560	930	16,5	350	300j6	400	5	18	4	
SUKg 225 M	60m6	140	18h9	64	505	300	630	1030	18	400	350j6	450	5	18	8	
SUKg 250 M	70m6	140	20h9	74,5	545	330	680	1190	19	500	450j6	550	5	18	8	
SUKg 280 S	80m6	170	22h9	85	610	360	790	1240	20	500	450j6	550	5	18	8	
SUKg 280 M	80m6	170	22h9	85	610	360	790	1290	20	500	450j6	550	5	18	8	

**FOOT MOUNTED MOTORS - IM B3
IP 44**

SUem 400

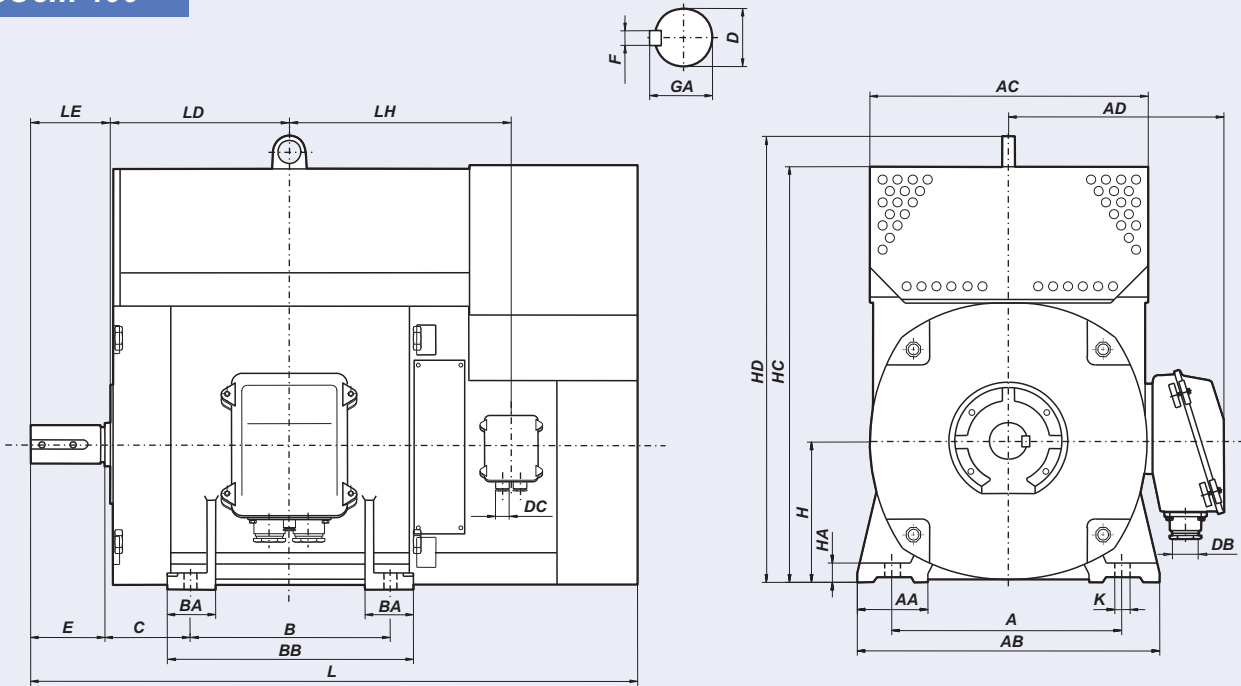

DIMENSION DRAWINGS

Type of motor	A	B	C	D	E	F	GA	H	HA	K	AA	AB	AC	AD	BA	BB	HC	HD	L	LD	LE	LH	DB	DC
SUem 400 S	686	560	280	110	210	28	116	400	50	35	155	850	790	590	175	700	1250	1340	1715	550	220	620	54	44
SUem 400 M	686	630	280	110	210	28	116	400	50	35	155	850	790	590	175	770	1250	1340	1785	585	220	655	54	44

**FOOT MOUNTED MOTORS - IM B3
IP 23**

SCUe 315 to 400

DIMENSION DRAWINGS

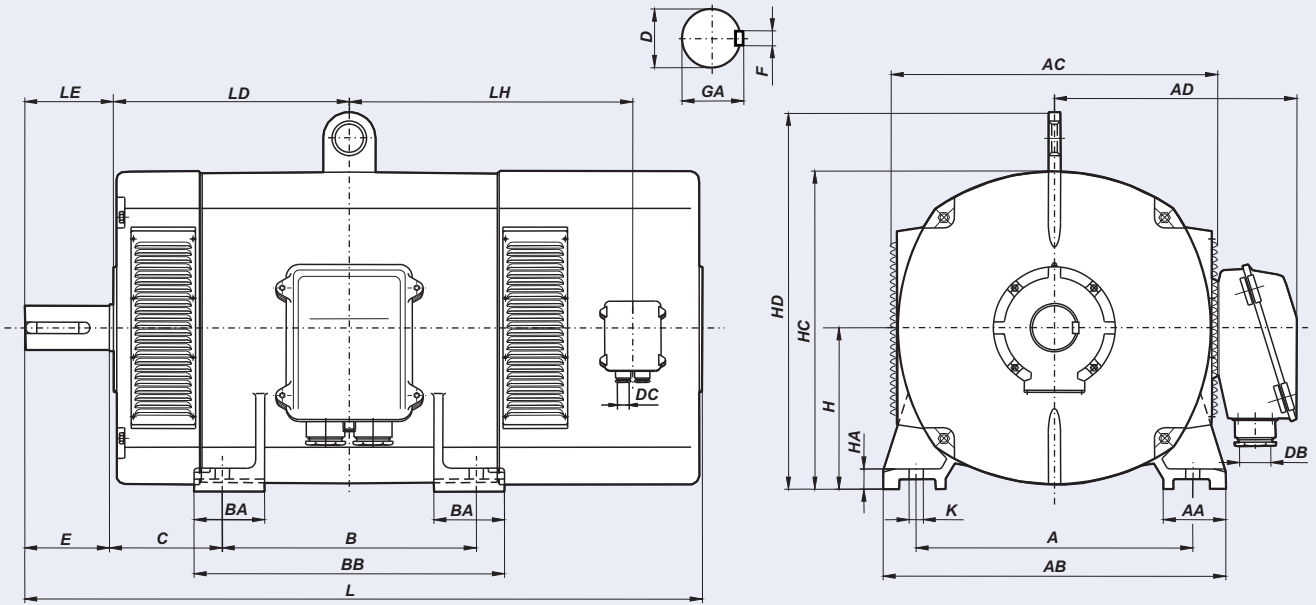

Type of motor	A	AA	AB	AC	AD	AE	B	BA	BB	C	D	E	F	GA	H	HA	HC	HD	K	L	LD	LE	LH	DB	DC
SCUe 315 S	508	130	620	637	480	318	406	120	490	216	90	170	25	95	315	30	620	718	28	1293	409	180	589	54	44
SCUe 315 M	508	130	620	637	480	318	457	120	540	216	90	170	25	95	315	30	620	718	28	1343	435	180	615	54	44
SCUe 355 S	610	130	730	674	498	337	500	130	590	254	100	210	28	106	355	35	695	810	28	1482	494	220	650	54	44
SCUe 355 M	610	130	730	674	498	337	560	130	650	254	100	210	28	106	355	35	695	810	28	1542	524	220	680	54	44
SCUe 400 S	686	155	850	790	601	405	560	175	700	280	110	210	28	116	400	50	795	920	35	1490	550	220	620	54	44
SCUe 400 M	686	155	850	790	601	405	630	175	770	280	110	210	28	116	400	50	795	920	35	1560	585	220	655	54	44

