

Goodrive600 Series

High-Performance Multi-drive VFD



CONTENTS



Company introduction	2
Product introduction	3
Multi-drive and high performance	4
Safe and reliable	6
Seamlessly integrated automatic control system.....	9
Technical specification	11
Type selection.....	12
Product overview	12
Module structure——rectifier unit.....	13
Rectifier unit selection	13
Module structure——inverter unit.....	13
Converter unit selection.....	14
Expansion card selection.....	14
Structure parts selection.....	15
Optional parts selection——main circuit	15
Installation dimension	16
Parallel combination	18
Wiring diagram.....	19
Installation instruction——expansion card	21
Installation instruction——external terminal of bus	22
Service network	23



Company introduction

INVT (Shenzhen INVT Electric Co., Ltd) has been concentrating on industry automation and energy power since its foundation in 2002 and is committed to "Providing the best product and service to allow customers more competitiveness". INVT goes public in 2010 and is the first A-share listed company (002334) in Shenzhen Stock Exchange in the industry. At present, INVT owns 16 subsidiaries and more than 3000 employees, over 30 domestic offices and warranty centers and 8 overseas branches, forming a sales network covering more than 60 overseas countries and regions.

INVT has been awarded as the Key High-tech Enterprise of National Torch Plan based on mastering of key technologies in power electronics, auto control and IT. With business covering industry automation, new-energy vehicle, network power and rail transit, INVT has established 12 R&D centers nationwide, boasts more than 850 patents and owns the first lab in the industry awarded ACT qualification from TUV SUD, UL-WTDP and CNAS National Lab. The industrial parks in Gongming and Suzhou aim to provide customers with advanced integrated product development design management, comprehensive

product R&D test and auto informational production. The worldwide INVT branches and warranty centers are ready to offer customers all-around back-ups including professional solutions, technical trainings and service support.

In the next decade, INVT will continue to take "Honesty and Integrity, Professionalism and Excellence" as our business philosophy, enhance core business sectors including industrial automation, new energy vehicle, network power and rail transit based on the three major technologies in industry automation and energy power fields, and strive to become a leading, responsible and harmonic international professional group armed with proper product structure, leading technologies, efficient management, robust profitability and superior competitiveness.



Suzhou Industrial park

East China industrial base and east China R&D center of group.



Guangming Industrial Park

Group headquarter and new product business development and incubation base.

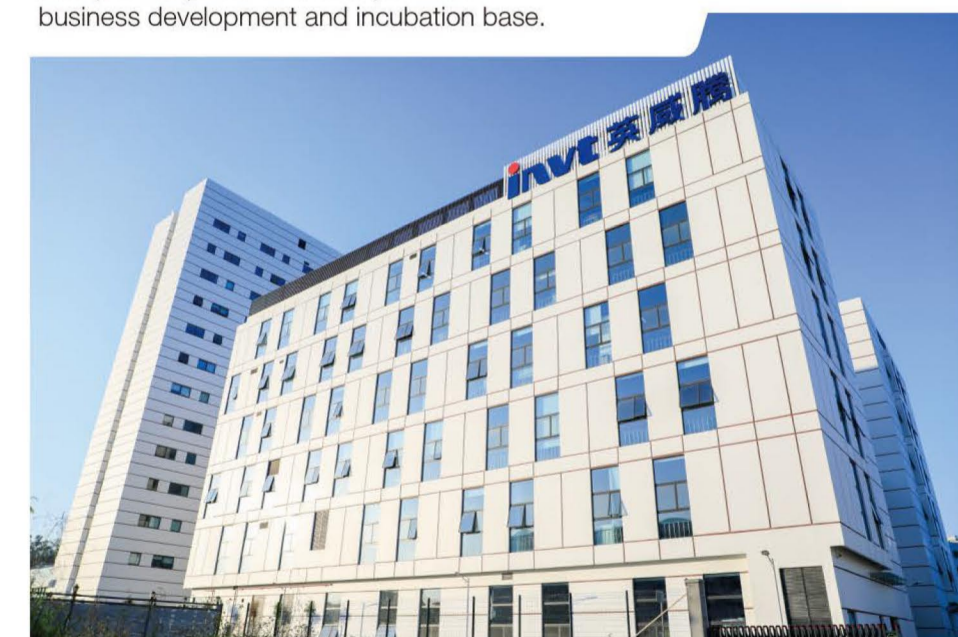

Product introduction

Goodrive600 Series High-Performance Multi-Drive VFD is a common DC bus multi-drive system, which adopts the book-type unit structure and integrated bus control. It features high power density, flexible communication networking, and strong extensibility, manifesting its incomparable advantages.

- Integrating the STO function
- Compatible with the mainstream fieldbus (1MB~100MB)
- Integrating torque control, speed control, and position control
- Implementing the driving control over asynchronous induction motors, permanent-magnet synchronous motors and servo motors
- Outstanding dynamic responding and control precision



Metal processing



Metallurgy



Printing&Packaging



Textile



Papermaking



Automatic production line

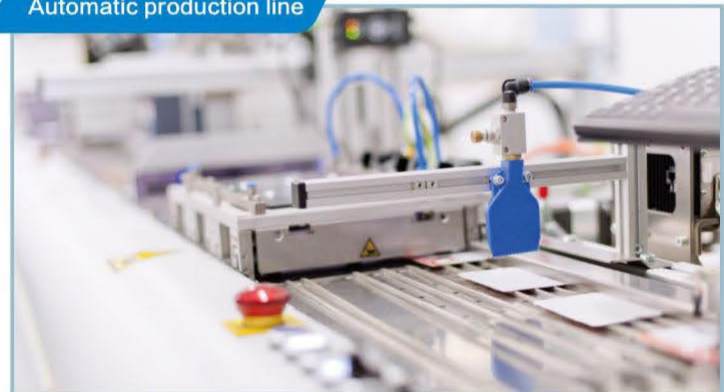

Multi-drive & high performance

- Equal-height and equal-depth book module design, totally **saves 30% space or more**.

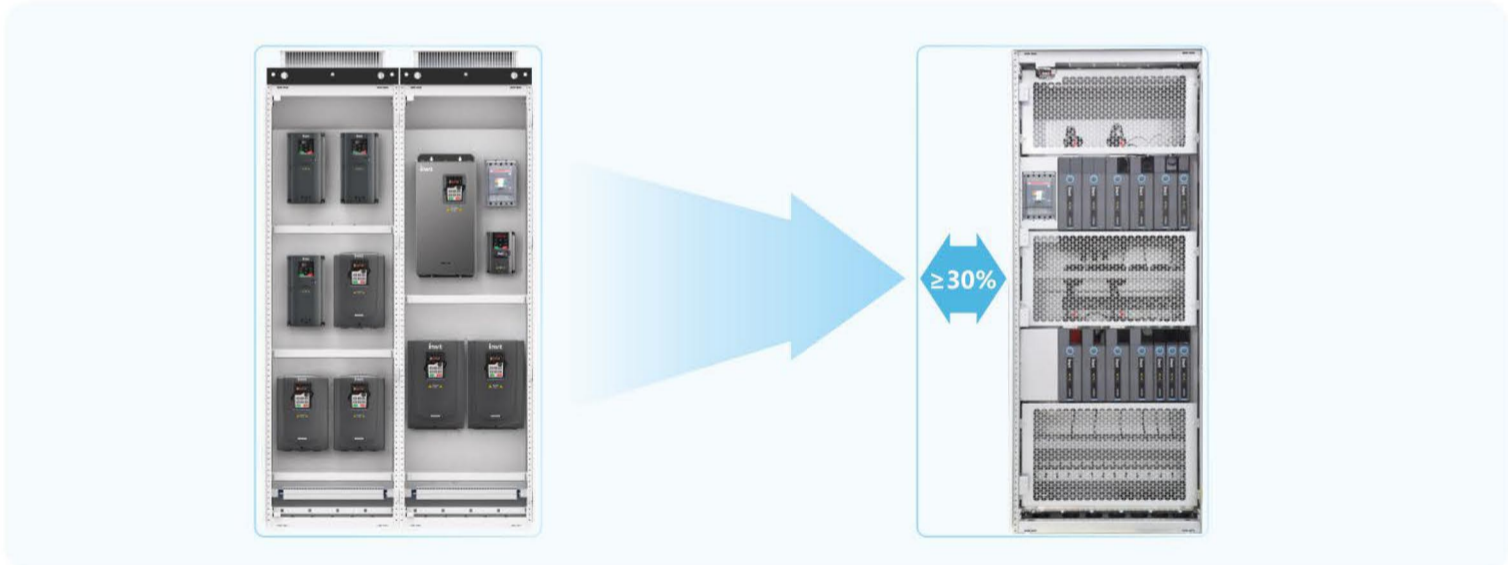

- Common dc bus realizes internal flow of energy, improves the electrical energy efficiency. It can **realize 30% of energy saving**.

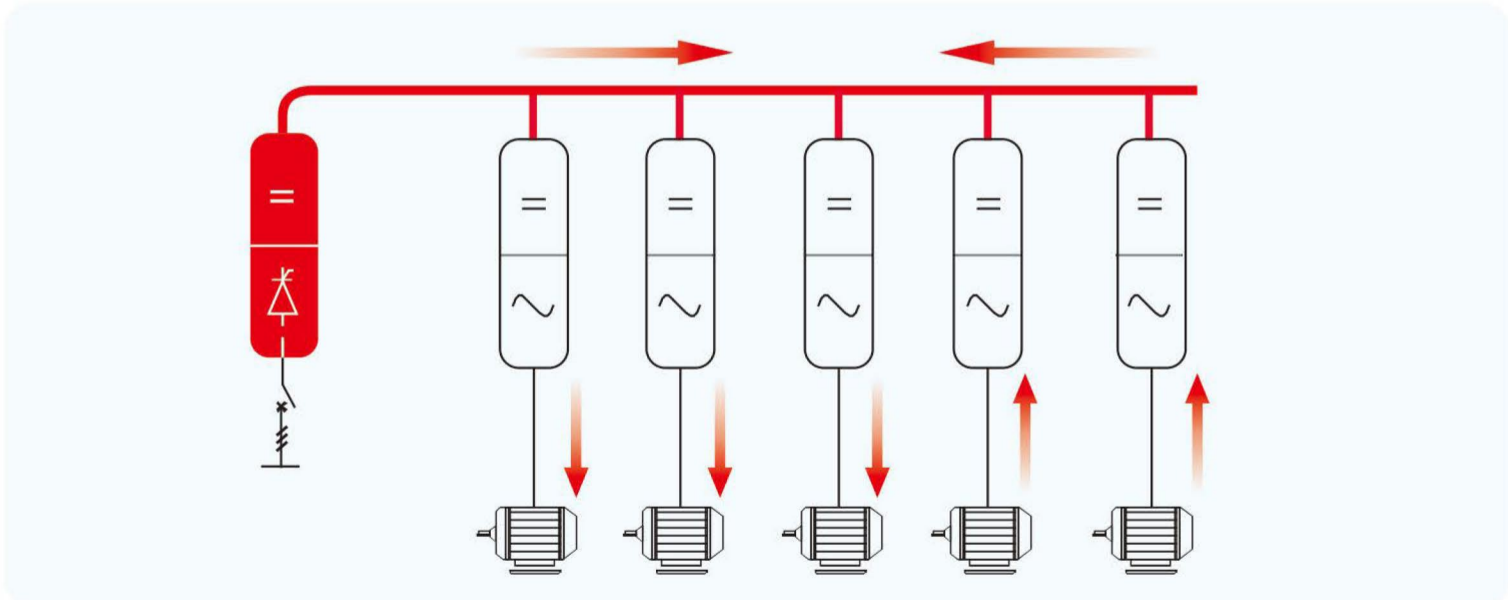

- Common dc bus effectively reduces the major circuit switch elements and redundant power cable of brake unit and system by unified power supply through rectifier units, to save system cost.

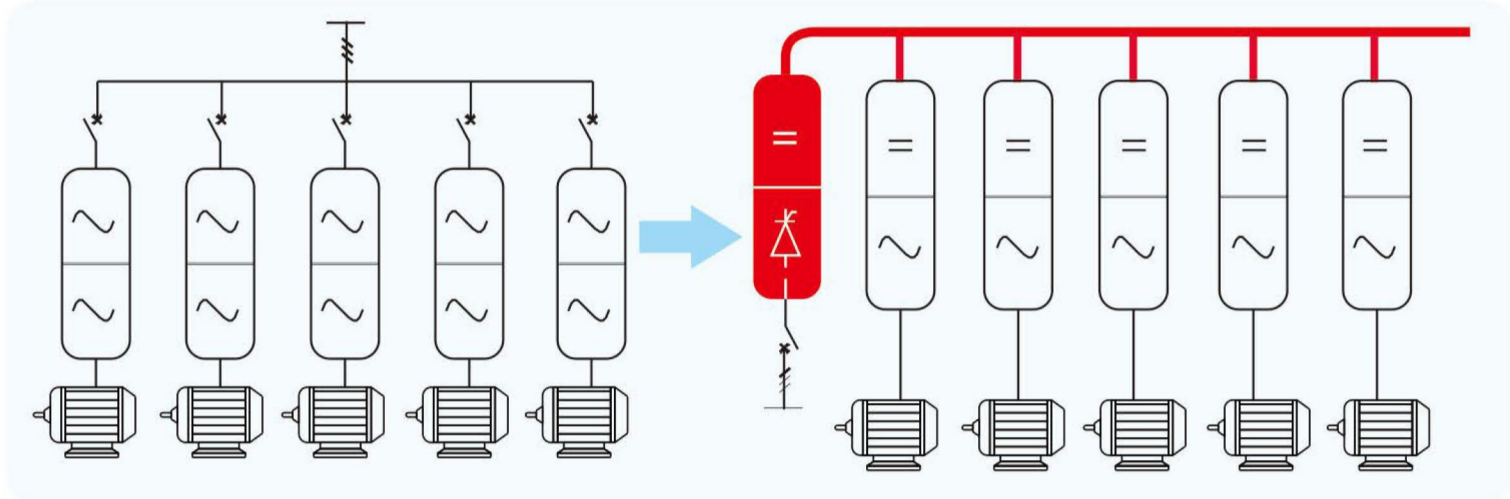

- Fast installation

External DC terminals can be used to facilitate the layered installation and maximize the utilization of the space in the cabinet.

The design allows quick lapping to DC buses and enables easy parallel operation, reducing the wiring time and costs.



- It combines asynchronous, synchronous and servo motor, making update easy.

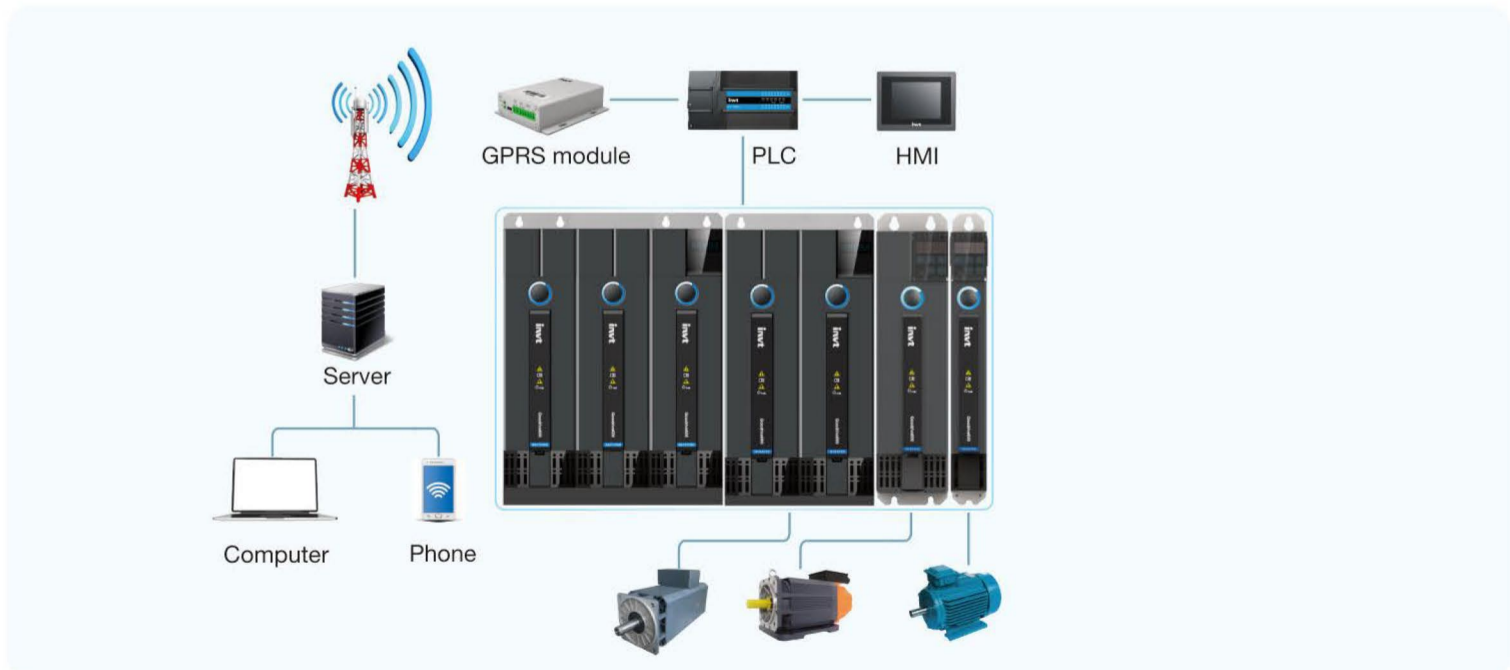

Safe and reliable

- PG card with digital filter technology improve anti-interference ability by more than one time, which insures the stable reception of encoder signal even over long distance.

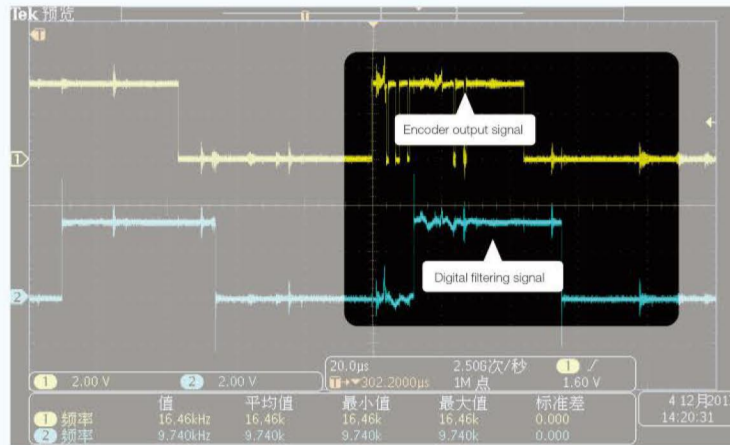

- Standard STO function——cut off torque output when motor stops, to avoid accidental activation and keep safe and reliable.

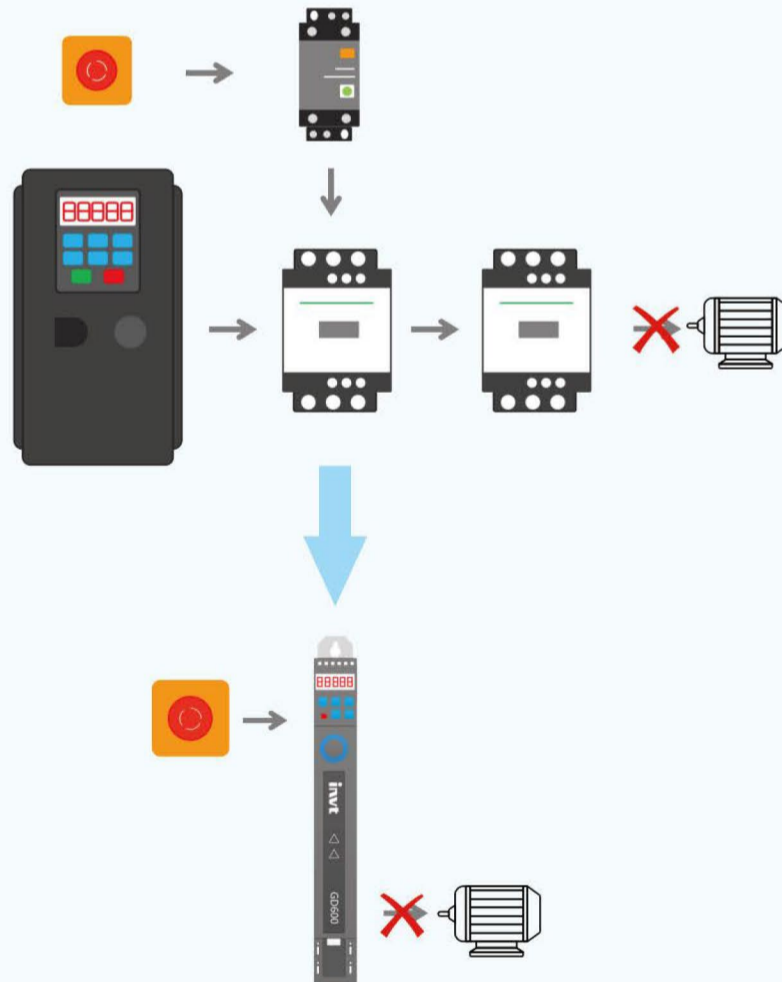

Note: level SIL3

- Perfect protection

The converter unit has a built-in DC fuse, preventing unit failure from spreading to the system, to improve system stability.



- Independent air duct

Independent air duct design, effectively prevent dust, particles and other pollutants into the VFD internal cause ignition and short circuit, improve product reliability, extend the service life.

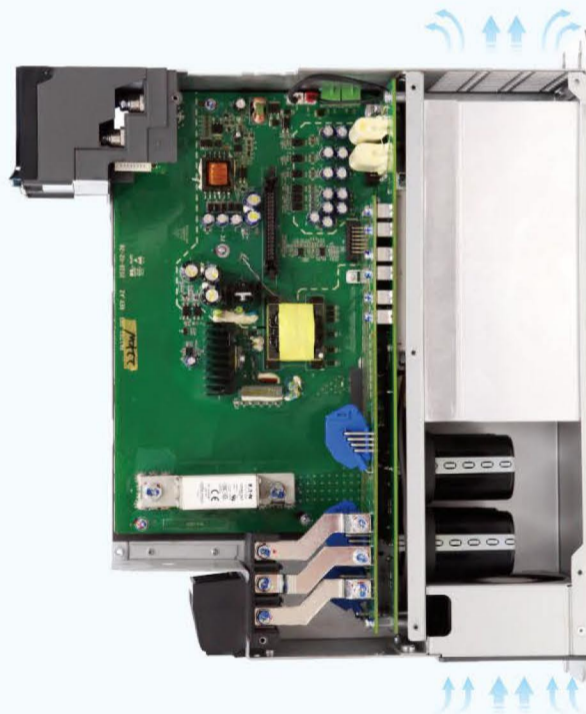

- Superior environmental adaptability

Automatic three-proofing spray technology, covered with more uniform coating coverage, comprehensively improve the protection ability of board.



- Perfect reliability test system insures the product suitable for the most complex application environment.

Test category	Test name	Segment types
Mechanical reliability test	Packaging test	Compression test of package
		Resonant scanning and resident experiment of package
		Random vibration test of package
		Drop test of package
		Rolling test of package
		Tilt drop test of package
		Italic impact test of package
	Impact test	Half-sine wave impact tes
		Trapezoidal wave impact test
		Sine wave vibration test
Vibration test	Random vibration experiment	
	Cryogenic storage experiment	
Climatic environment reliability test	Temperature test	High temperature storage experiment
		Low temperature work experiment
		High temperature work experiment
		Temperature gradient experiment
		Temperature impact experiment
		Constant moist experiment
	Moist test	Mutational moist experiment
		Continuous salt spray experiment
	Salt spray test	Mutational salt spray experiment
		Comprehensive experiment of low temperature and low pressure
	Low-pressure test	Comprehensive experiment of high temperature and low pressure

Note:

INVT is first domestic factory to achieve the ACT qualification issued by TÜV SÜD. ACT is the short of Acceptance of Client's Testing. It tells that TÜV SÜD of Germany officially recognizes the technical level of a company's laboratory, officially recognizes the test data issued by this laboratory, and receives the test report issued by this laboratory.



Electric vibration experiment



Low pressure text box (left)
Constant temperature and humidity test box (right)



Natural convection test box (left)
Cold and hot shock test box (right)

Seamlessly integrated automatic control system

PLC+Standard Modbus

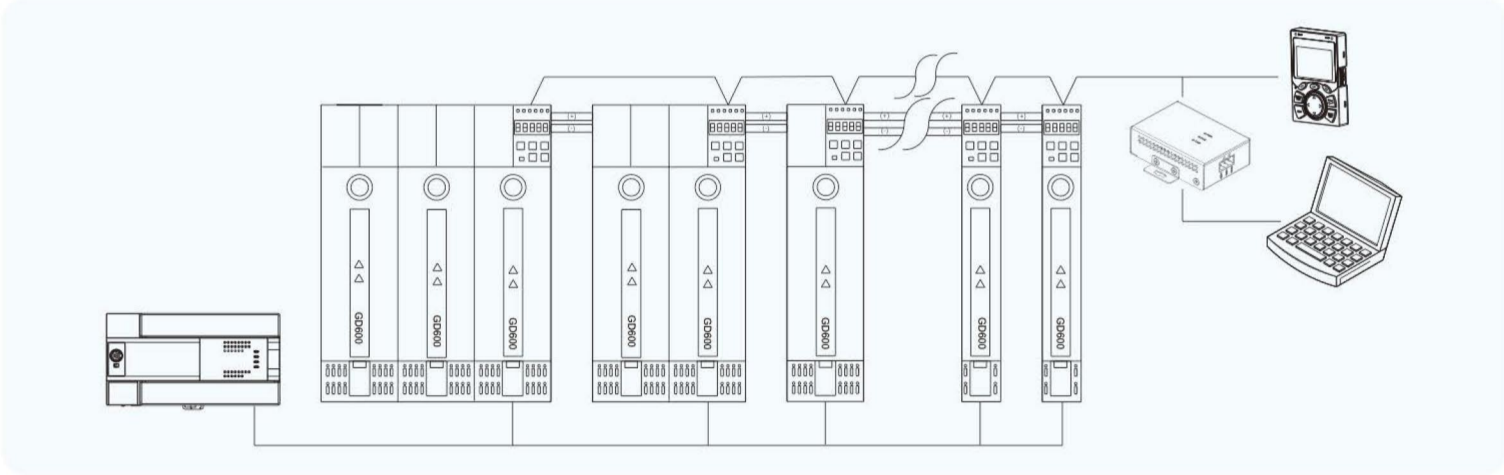

PLC+Standard CANopen

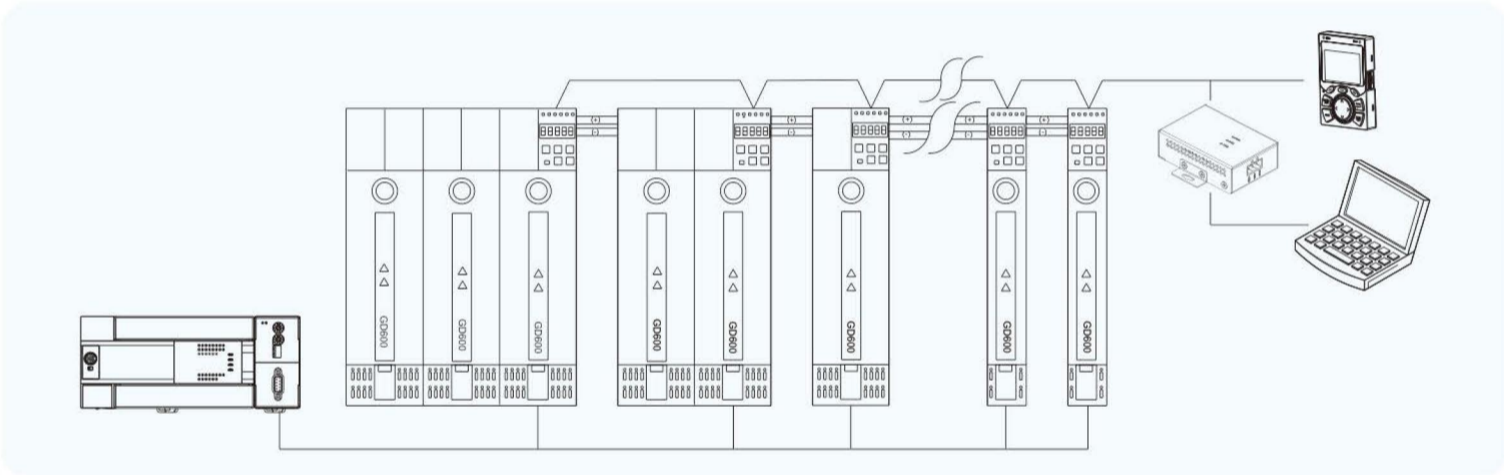

Optional PLC Card+Standard CANopen

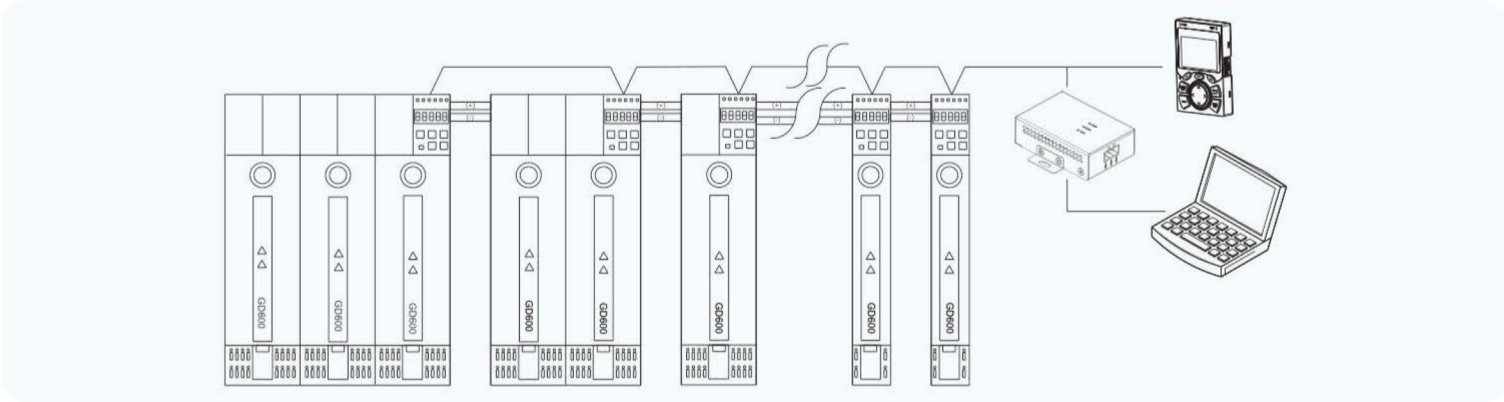

PLC+Optional PROFIBUS-DP

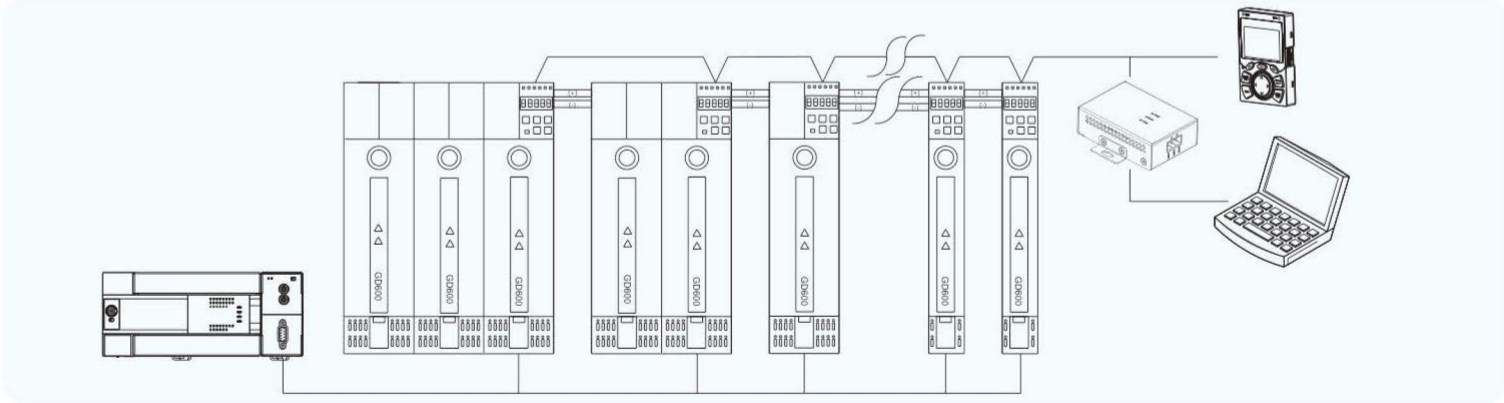

PLC+Optional PROFINET/ Optional EtherCAT

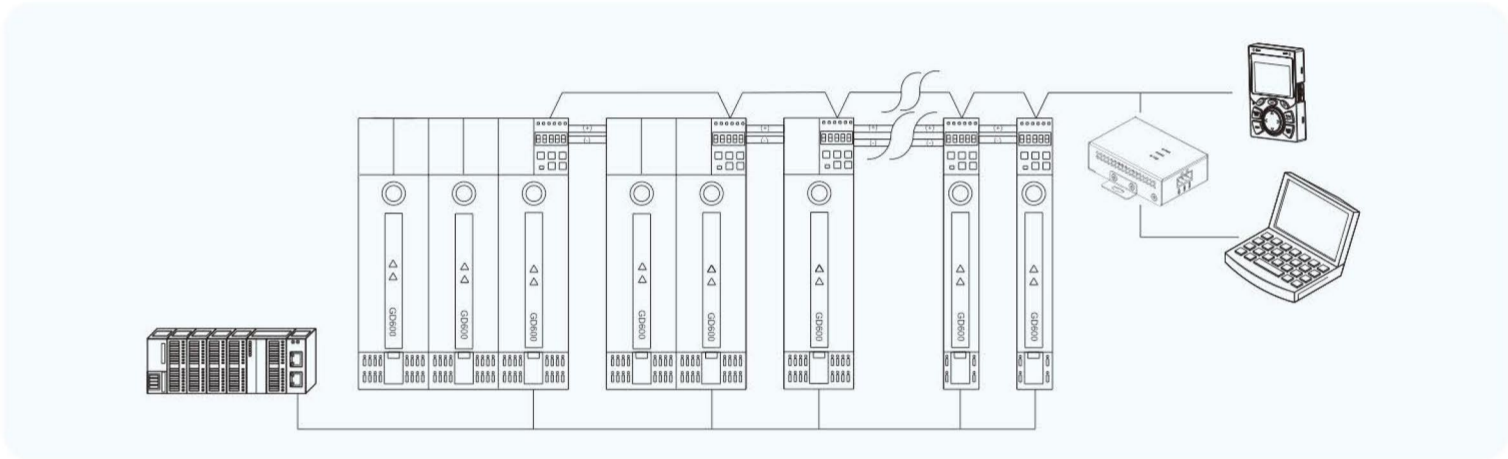

PLC+Optional PROFIBUS-DP/CANopen bridge network

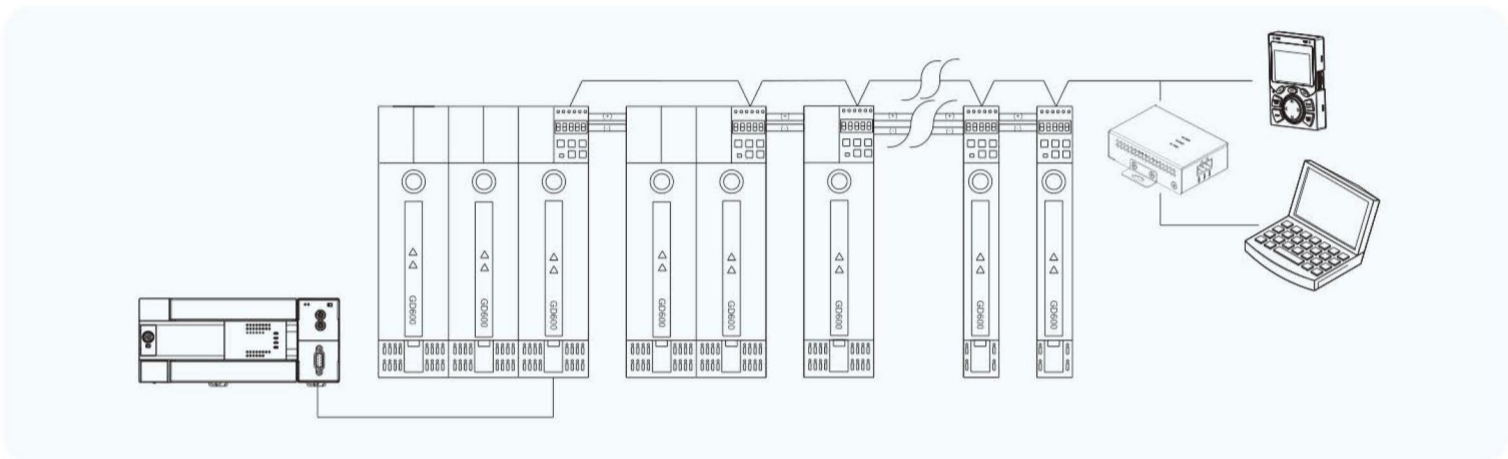

PLC+Optional PROFINET/CANopen bridge network

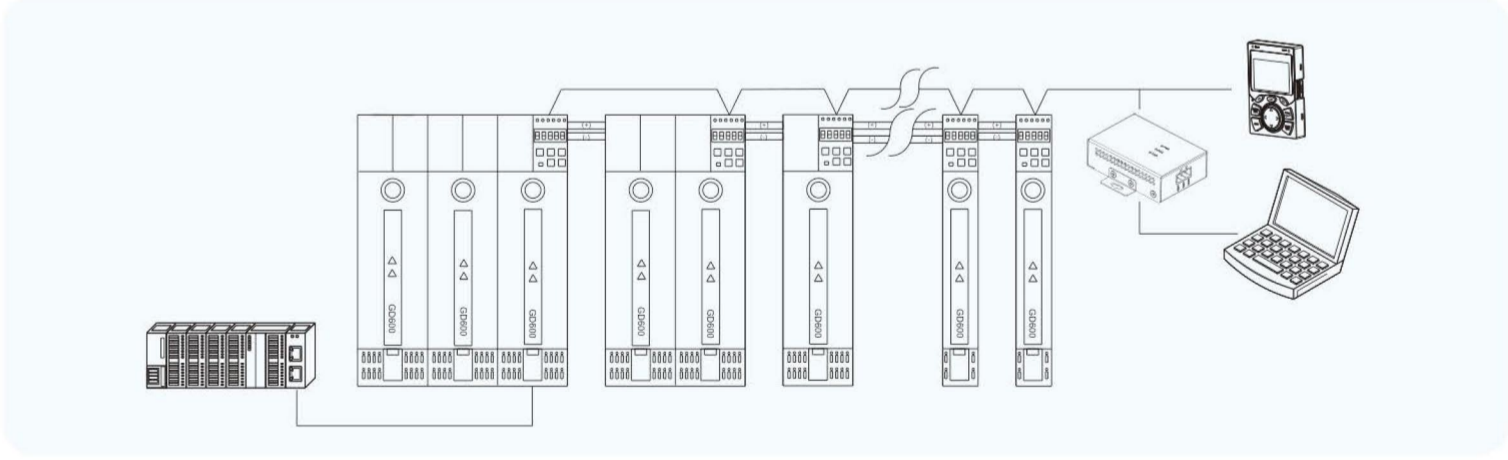

PLC+Optional EtherCAT/CANopen bridge network

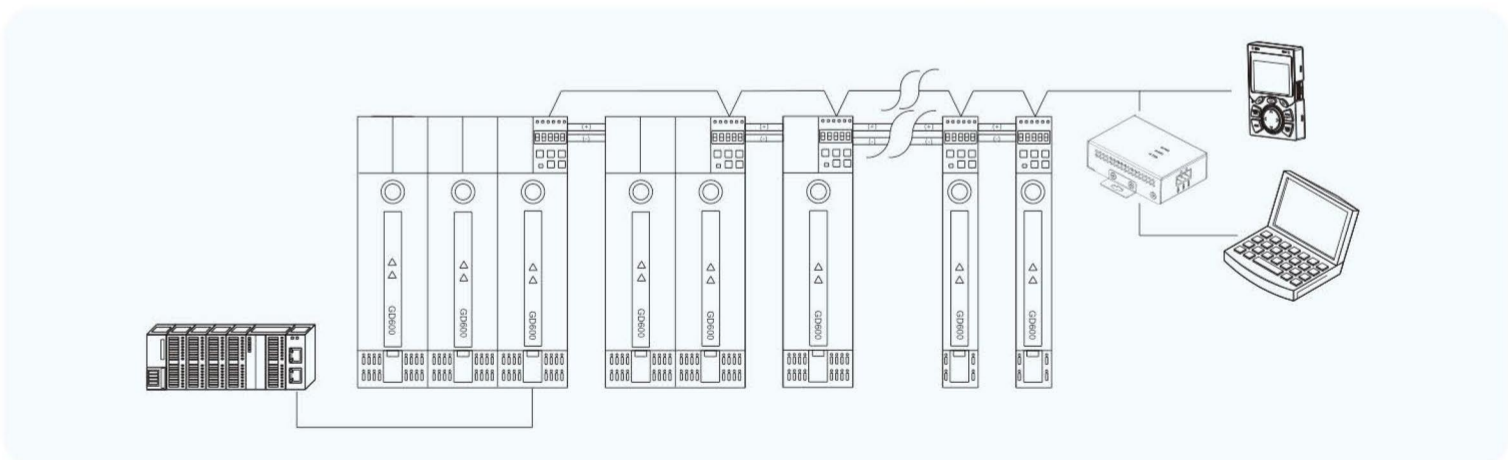

Technical specification

Function description		Specifications indicators
Technical control performance	Output frequency(Hz)	0~400Hz
	Carrier frequency(Hz)	1.0~15kHz
	Control mode	SVPWM control, SVC, VC
	Motor type	Asynchronous motor, permanent-magnet synchronous motor
	Speed regulation ratio	Asynchronous motor 1:200(SVC); Synchronous motor 1:20(SVC); Asynchronous motor 1:1000(VC)
	Speed control precision	±0.2%(SVC), ±0.02%(VC)
	Speed fluctuation	±0.3%(SVC), ±0.02%(VC)
	Torque response	<20ms(SVC); <10ms(VC)
	Torque control precision	±10%(SVC); ±5%(VC)
	Starting torque	Asynchronous motor: 0.25Hz/150% (SVC) Synchronous motor: 2.5 Hz/150% (SVC) 0Hz/200% (VC)
	Overload capacity	150%: 1min; 180%: 10s; 200%: 1s;
Running control performance	Frequency setup mode	Digital, analog, pulse frequency, multi-step speed running, simple PLC, PID, MODBUS, PROFIBUS, PROFINET, ETHERCAT, etc. Realize switch-over between the set combination and the set channel
	Automatic voltage regulation function	Keep the output voltage constant when grid voltage changes
	Speed tracking restart function	Realize impact-free starting of the motor in rotating
External interface	Analog input	2, AI1: 0~10V/0~20mA, AI2: -10~10V Resolution: no more than 20mA
	Analog output	1, AO1: 0~10V/0~20mA
	Digital input	4 outputs, max. frequency: 1kHz, Internal impedance: 3.3k Resolution: no more than 2ms
	Digital output	1 Y terminal open collector output
	Relay output	2 programmable relay outputs RO1A NO, RO1B NC, RO1C common port RO2A NO, RO2B NC, RO2C common port Contact capacity: 3A/AC250V, 1A/DC30V
	Communication interface	1 RS485 interface, supporting Modbus; 1 CAN interface for synchronous control
	External interface	2 extension interface: SLOT1, SLOT2; Expandable PG card, programmable extension card, communication card, I/O card, etc.
Protection function	Rectifier unit	Input out-phase, input overvoltage, input unbalanced 3PH voltage, overcurrent protection of brake circuit, short-circuit protection of brake resistance, direction protection of brake pipe protection, overvoltage, undervoltage, over-temperature
	Converter unit	Provide more than 30 fault protection functions: earthing short circuit, phase short circuit, overcurrent, overvoltage, undervoltage, overheating, phase loss, overload, overheating, communication fault, stall, encoder fault, etc.
Others	Installation mode	Wall-mounting, flange-mounting
	Temperature of running environment	-10~50°C, derating is required if the ambient temperature exceeds 40°C
	Protection level	IP20
	Pollution level	Level 2
	Cooling mode	Forced air cooling





Type selection

GD600
-71
-045
-4
-B

1
2
3
4
5

Field	Identification	Description
Product series	①	GD600: Goodrive600 high-performance multi-function VFD
Product type	②	51: Converter unit 71: Main control rectifier unit
Power code	③	045: 45kW
Voltage class	④	4: AC 3PH 380V(-15%)~440V(+10%) Rated voltage: 380V
Management of no.	⑤	None: default B: Built-in brake unit

Product overview

Appearance						
	Rectifier unit			Converter unit		
Power (kW)	45	160	355	1.5~7.5	11~37	45~75
Dimension (W*H*D)	100*355*350	300*355*350	180*805*423	50*355*350	100*355*350	200*355*350
Optional part						
Type	PLC card	Communication card		PG card		I/O card

Remark: Rectifier unit is not allowed to install PG card.

Module structure——rectifier unit

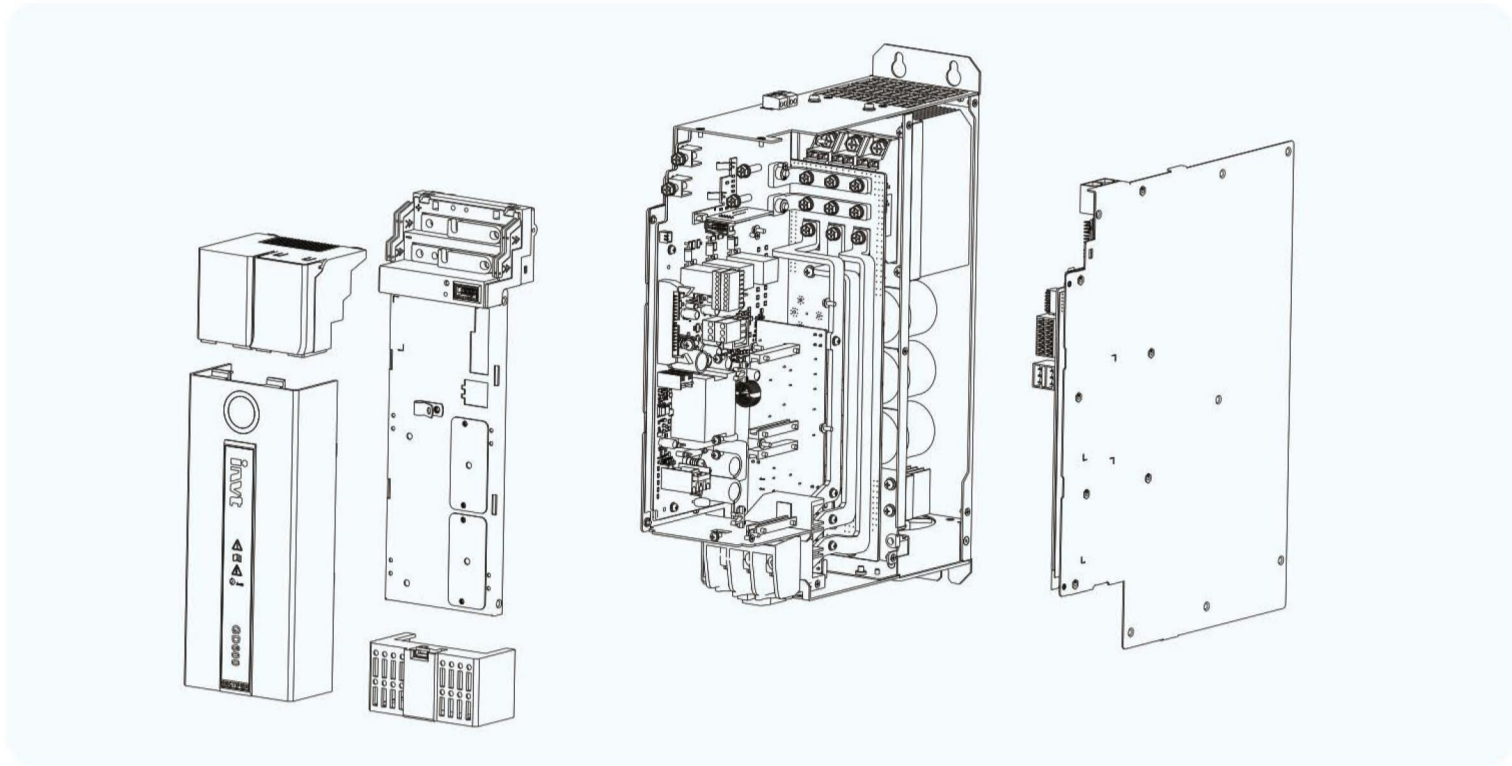

Rectifier unit selection

Input voltage: AC 3PH 380V(-15%)~440V(+10%), Output voltage: 457Vdc~684Vdc

Product model	Rated power (kW)	Power capacity (kVA)	Input current AC(A)	Output current DC(A)	Built-in bus current-carrying capacity (A)	Recommended brake unit	Recommended braking resistor (OHM)
GD600-71-045-4-B	45	76	110	135	200	Built-in	≥6.4
GD600-71-160-4	160	215	320	380	200	DBU100H- 320-4	≥2.2
GD600-71-355-4	355	433	625	766	200	DBU100H-320-4×2	≥2.2*2



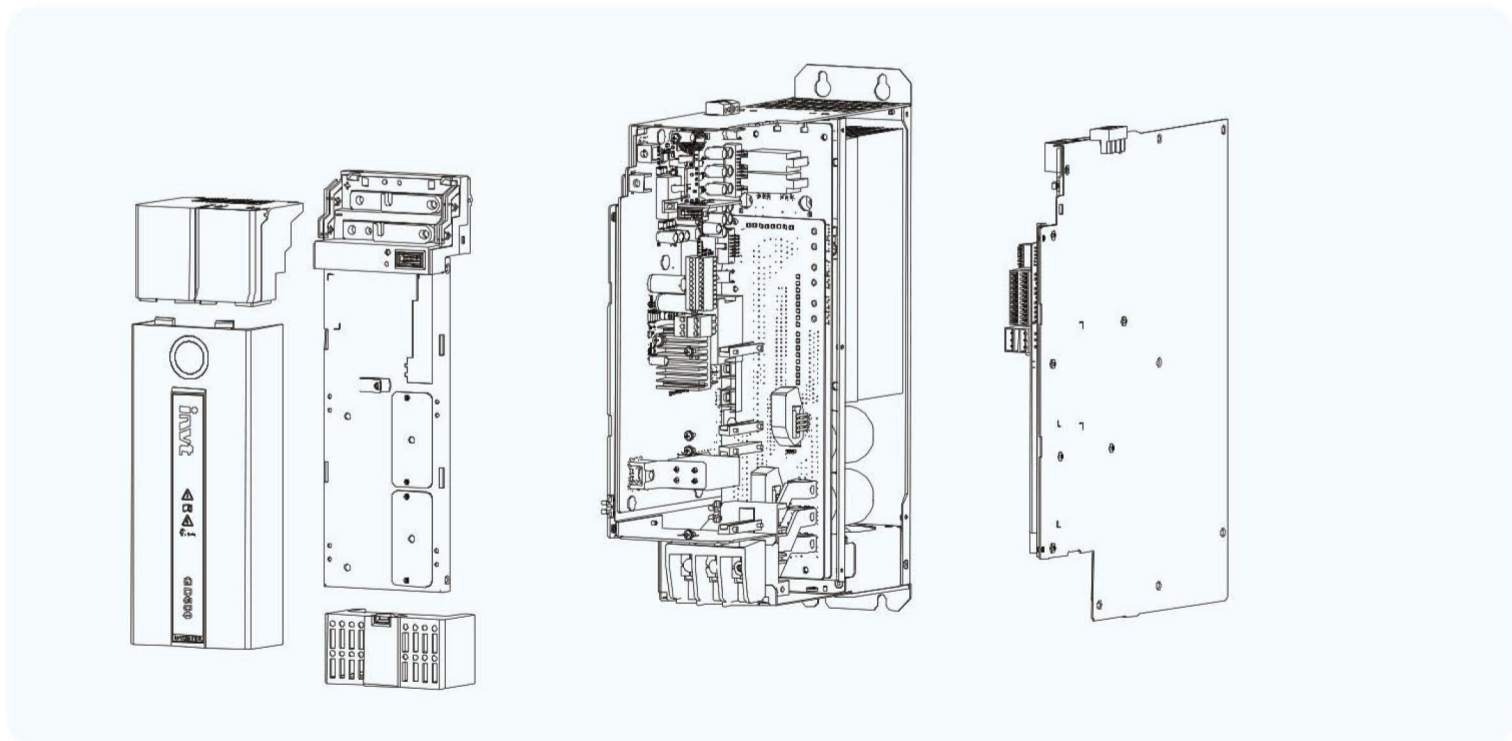

Module structure——converter unit







Converter unit selection

Input voltage: 457Vdc~684Vdc (working range: 350Vdc~800Vdc), Output voltage: 0~480Vdc						
Product model	Rated power (kW)	Input current DC(A)	Output current DC (A)	Built-in bus current-carrying capacity (A)	Motor	
					(kW)	(HP)
GD600-51-1R5-4	1.5	3.6	3.7	100	1.5	2
GD600-51-2R2-4	2.2	5.5	5.5	100	2.2	3
GD600-51-004-4	4	9.6	9.5	100	3.7	5
GD600-51-5R5-4	5.5	14.2	14	100	5.5	7.5
GD600-51-7R5-4	7.5	19	18.5	100	7.5	10
GD600-51-011-4	11	26	25	200	11	15
GD600-51-015-4	15	33	32	200	15	20
GD600-51-018-4	18.5	40	38	200	18.5	25
GD600-51-022-4	22	47	45	200	22	30
GD600-51-030-4	30	62	60	200	30	40
GD600-51-037-4	37	79	75	200	37	50
GD600-51-045-4	45	97	92	200	45	60
GD600-51-055-4	55	121	115	200	55	75
GD600-51-075-4	75	158	150	200	75	100

Expansion card selection

Type	model	category	Specification
 PG card	EC-PG705-12	Multi-function incremental PG card	Applicable to OC encoders and push-pull encoders of 5V or 12V; Maximum 200kHz; Supporting pulse string setting; Supporting 5V OC 1~255 octave output;
	EC-PG704	Resolver transformer PG card	Resolver transformer encoder; Supporting pulse/direction OC input; Maximum 200kHz; Supporting 5V OC 2n(1~255) octave output;
	EC-PG707-24	24V incremental PG card	Applicable to OC encoders and push-pull encoders of 5V or 12V; Supporting the orthogonal signal of A, B and Z; Maximum 200kHz;
 Communication card	EC-TX703	PROFIBUS-DP	PROFIBUS protocol, 9.6kbps~12Mbps
	EC-TX709	PROFINET	PROFINET protocol; Supporting 100Mbps full-duplex operation
	EC-TX704	Upper computer card	INVT Ethernet protocol; Used for INVT Workshop upper computer monitoring
	EC-TX708	EtherCAT card	Support EtherCAT protocol. Can be used for EtherCAT slave station. Support 100Mbps/s full duplex operation.
 PLC card	EC-PC701-01	PLC card	4DI 2RO; 128k user data storage; 64k data storage space; Supporting IL, SF, FBD, LD, CFC, SFC, etc.
 I/O card	EC-IO702	I/O card	Support 2 digital inputs, 1 analog input, 1 relay output, 4 kinds temperature detection(KTY84-130/PT100/PT1000/NTC)

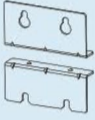
Structure parts selection

Name	picture	Model/Order number	specification	Adaptable model
LCD keypad		SOP-600-01	LCD keypad	All
		19005-00149	External keypad bracket	All
		37005-00022	3m outer cable	All
Outer terminal		GD600-CON1	100A outer terminal	Converter unit (≤ 7.5 kW)
		GD600-CON2	200A outer terminal	Converter unit (> 11 kW) 45kW/60kW rectifier unit
shielding shelf		GD600-SH1	50mm shielding shelf	Converter unit (1.5-7.5kW)
		GD600-SH2	100mm shielding shelf	Converter unit (11-37kW)
Flange-mounted shelf		GD600-FLAN1	50mm mounting bracket	Converter unit (1.5-7.5kW)
		GD600-FLAN2	100mm mounting bracket	Converter unit (11-37kW) ; Rectifier unit (45kW)
		GD600-FLAN3	200mm mounting bracket	Converter unit (45-75kW)
		GD600-FLAN4	300mm mounting bracket	Rectifier unit (160kW)
Air deflector		GD600-AD1	50mm lead wind board	Converter unit (1.5-7.5kW)
		GD600-AD2	100mm lead wind board	Converter unit (11-37kW) ; Rectifier unit (45kW)
		GD600-AD3	200mm lead wind board	Converter unit (45-75kW)
		GD600-AD4	300mm lead wind board	Rectifier unit (160kW)
USB-485		EC-TM485-USB	Adaptor	All, GD600 unit top RJ45 interface cannot connect to PC directly, need to use USB-485 adaptor

Optional parts selection main circuit

Type	Model	Rated power (kW)	Reactor	Filter
Rectifier part	GD600-71-045-4-B	45	ACL2-045-4	FLT-P04100L-B
	GD600-71-160-4	160	ACL2-160-4	FLT-P04400L-B
	GD600-71-350-4	350	ACL2-350-4	FLT-P04800L-B
Converter part	GD600-51-1R5-4	1.5	OCL2-1R5-4	FLT-L04006L-B
	GD600-51-2R2-4	2.2	OCL2-2R2-4	
	GD600-51-004-4	4	OCL2-004-4	FLT-L04016L-B
	GD600-51-5R5-4	5.5	OCL2-5R5-4	FLT-L04032L-B
	GD600-51-7R5-4	7.5	OCL2-7R5-4	
	GD600-51-011-4	11	OCL2-011-4	
	GD600-51-015-4	15	OCL2-015-4	FLT-L04045L-B
	GD600-51-018-4	18.5	OCL2-018-4	FLT-L04065L-B
	GD600-51-022-4	22	OCL2-022-4	
	GD600-51-030-4	30	OCL2-030-4	FLT-L04100L-B
	GD600-51-037-4	37	OCL2-037-4	
	GD600-51-045-4	45	OCL2-045-4	
	GD600-51-055-4	55	OCL2-055-4	FLT-L04150L-B
	GD600-51-075-4	75	OCL2-075-4	

Installation dimension

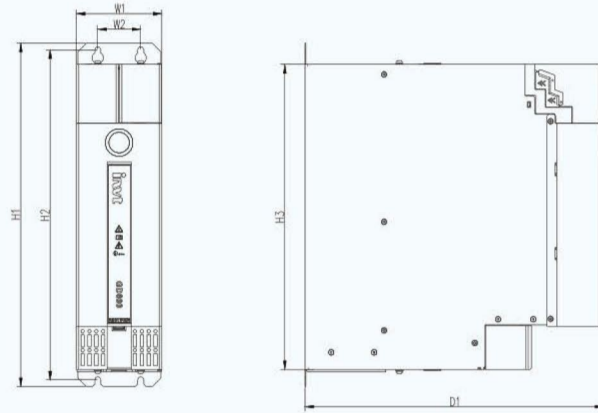

Model	Overall dimensions (mm)			Installation hole location (mm)			Installation hole size (mm)	Weight (kg)
	W1	H1	D1	W2	H2	H3		
GD600-71-045-4-B	100	400	350	50	384	355	Φ7	9

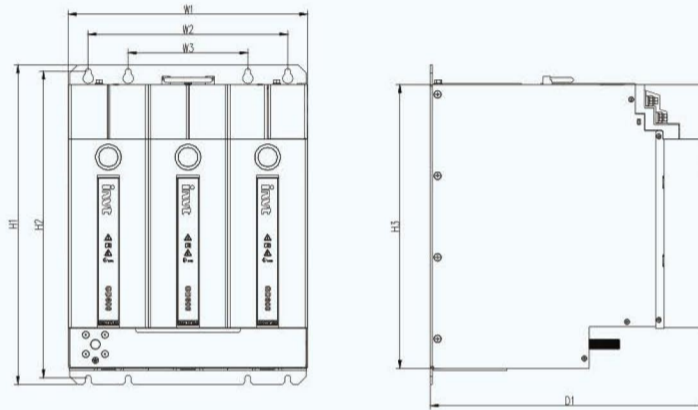

Model	Overall dimensions (mm)			Installation hole location (mm)				Installation hole size (mm)	Weight (kg)
	W1	H1	D1	W2	W3	H2	H3		
GD600-71-160-4	300	350	250	250	150	384	355	Φ7	28

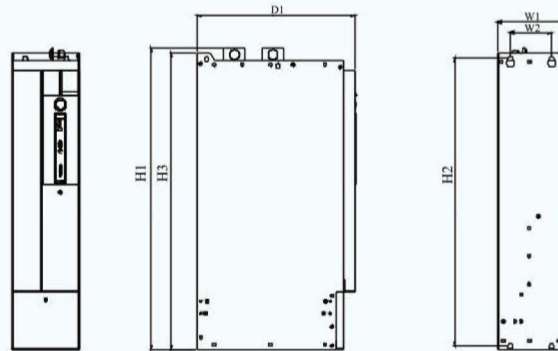

Model	Overall dimensions (mm)			Installation hole location (mm)			Installation hole size (mm)	Weight (kg)
	W1	H1	D1	W2	H2	H3		
GD600-71-355-4	180	805	423	110	767.5	790	Φ11	42.6

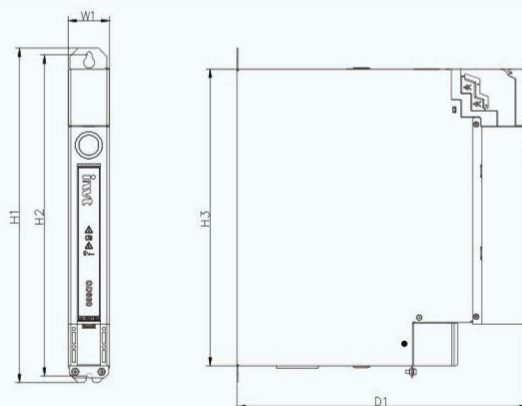

Model	Overall dimensions (mm)			Installation hole location (mm)			Installation hole size (mm)	Weight (kg)
	W1	H1	D1	W2	H2	H3		
GD600-51-1R5-4	50	400	350	-	384	355	Φ7	4
GD600-51-2R2-4	50	400	350	-	384	355	Φ7	4
GD600-51-004-4	50	400	350	-	384	355	Φ7	4
GD600-51-5R5-4	50	400	350	-	384	355	Φ7	4
GD600-51-7R5-4	50	400	350	-	384	355	Φ7	4

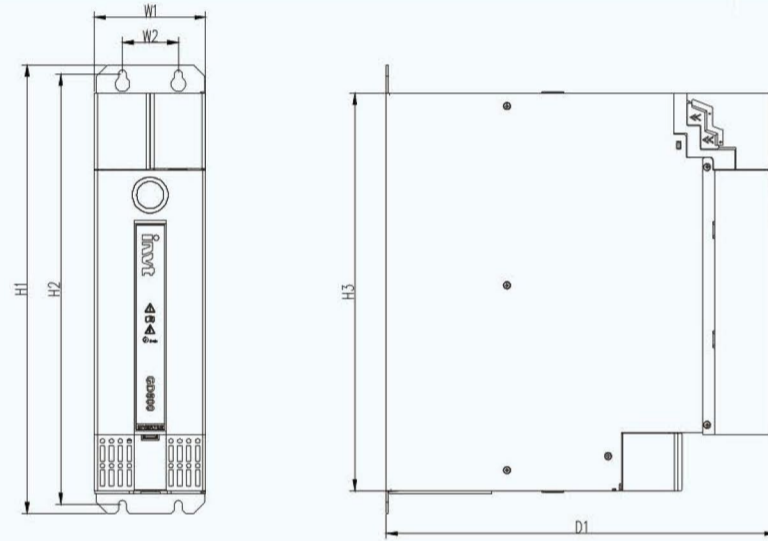

Model	Overall dimensions (mm)			Installation hole location (mm)			Installation hole size (mm)	Weight (kg)
	W1	H1	D1	W2	H2	H3		
GD600-51-011-4	100	400	350	50	384	355	Φ7	9
GD600-51-015-4	100	400	350	50	384	355	Φ7	9
GD600-51-018-4	100	400	350	50	384	355	Φ7	9
GD600-51-022-4	100	400	350	50	384	355	Φ7	9
GD600-51-030-4	100	400	350	50	384	355	Φ7	9
GD600-51-037-4	100	400	350	50	384	355	Φ7	9

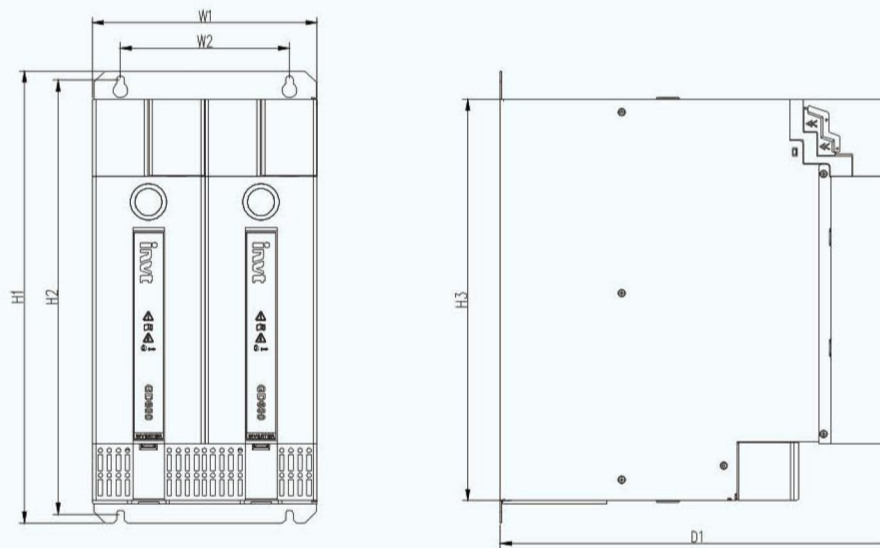

Model	Overall dimensions (mm)			Installation hole location (mm)			Installation hole size (mm)	Weight (kg)
	W1	H1	D1	W2	H2	H3		
GD600-51-045-4	200	400	350	150	384	355	Φ7	18
GD600-51-055-4	200	400	350	150	384	355	Φ7	18
GD600-51-075-4	200	400	350	150	384	355	Φ7	18

Parallel combination

Combination mode	Parallel figure	Satisfied condition
Single row distribution (Rectifier on the left)		$I \geq 0.8 * (I1 + I2 + I3 + I4 + I5 + I6 + \dots)$ $I1 + I2 + I3 + I4 + I5 + I6 + \dots \leq 200A$ $I4 + I5 + I6 + \dots \leq 100A$
Single row distribution (Rectifier in the middle)		$I \geq 0.8 * (I1 + I2 + I3 + I4 + I5 + I6 + I7 + \dots)$ $I1 + I2 + I3 + \dots \leq 200A$ $I4 + I5 + I6 + I7 + \dots \leq 200A$ $I5 + I6 + I7 + \dots \leq 100A$ $I3 + \dots \leq 100A$
Single row distribution (External bus)		$I \geq 0.8 * (I1 + I2 + I3 + I4 + I5 + I6 + \dots)$ $I1 + I2 \leq 200A$ $I3 + I4 + I5 + I6 + \dots \leq 200A$ $I4 + I5 + I6 + \dots \leq 100A$
Double row distribution (single rectifier)		$I \geq 0.8 * (I1 + I2 + I3 + I4 + I5 + I6 + I7 + \dots)$ $I1 + I2 + I3 + \dots \leq 200A$ $I4 + I5 + I6 + I7 + \dots \leq 200A$ $I5 + I6 + I7 + \dots \leq 100A$ $I3 + \dots \leq 100A$
Multiple row distribution (Multiple rectifier switch in parallel)		$I + I1 \geq 0.8 * (I1 + I2 + I3 + I4 + I5 + I6 + I7 + \dots)$ $I / I1 \approx (I1 + I2 + I3 + \dots) / (I4 + I5 + I6 + I7 + \dots)$ $I1 + I2 + I3 + \dots \leq 200A$ $I4 + I5 + I6 + I7 + \dots \leq 200A$ $I5 + I6 + I7 + \dots \leq 100A$ $I3 + \dots \leq 100A$ <p>Note: Parallel installation is not supported among rectifier units of different power</p>

Wiring diagram

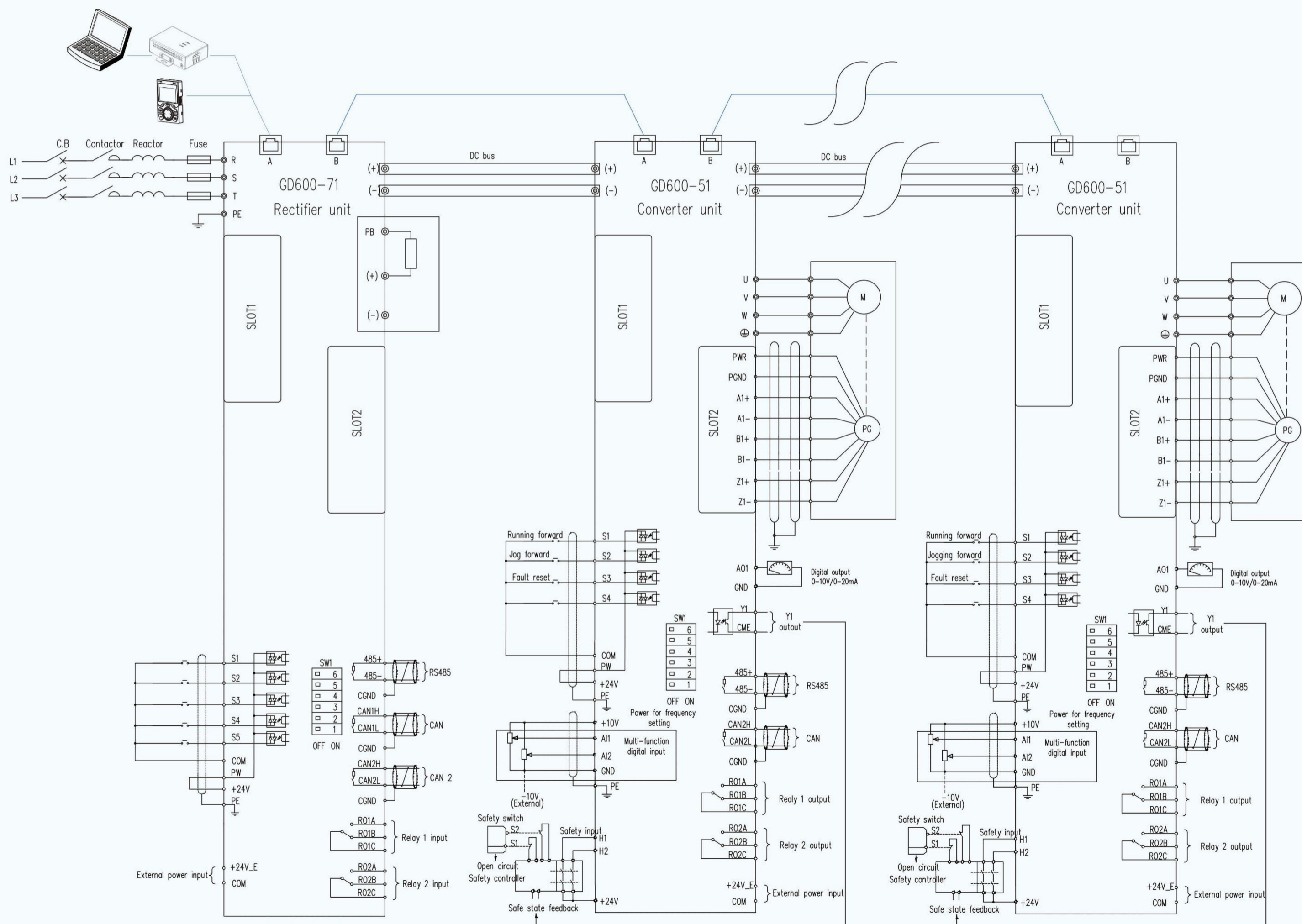

Installation instruction——expansion card

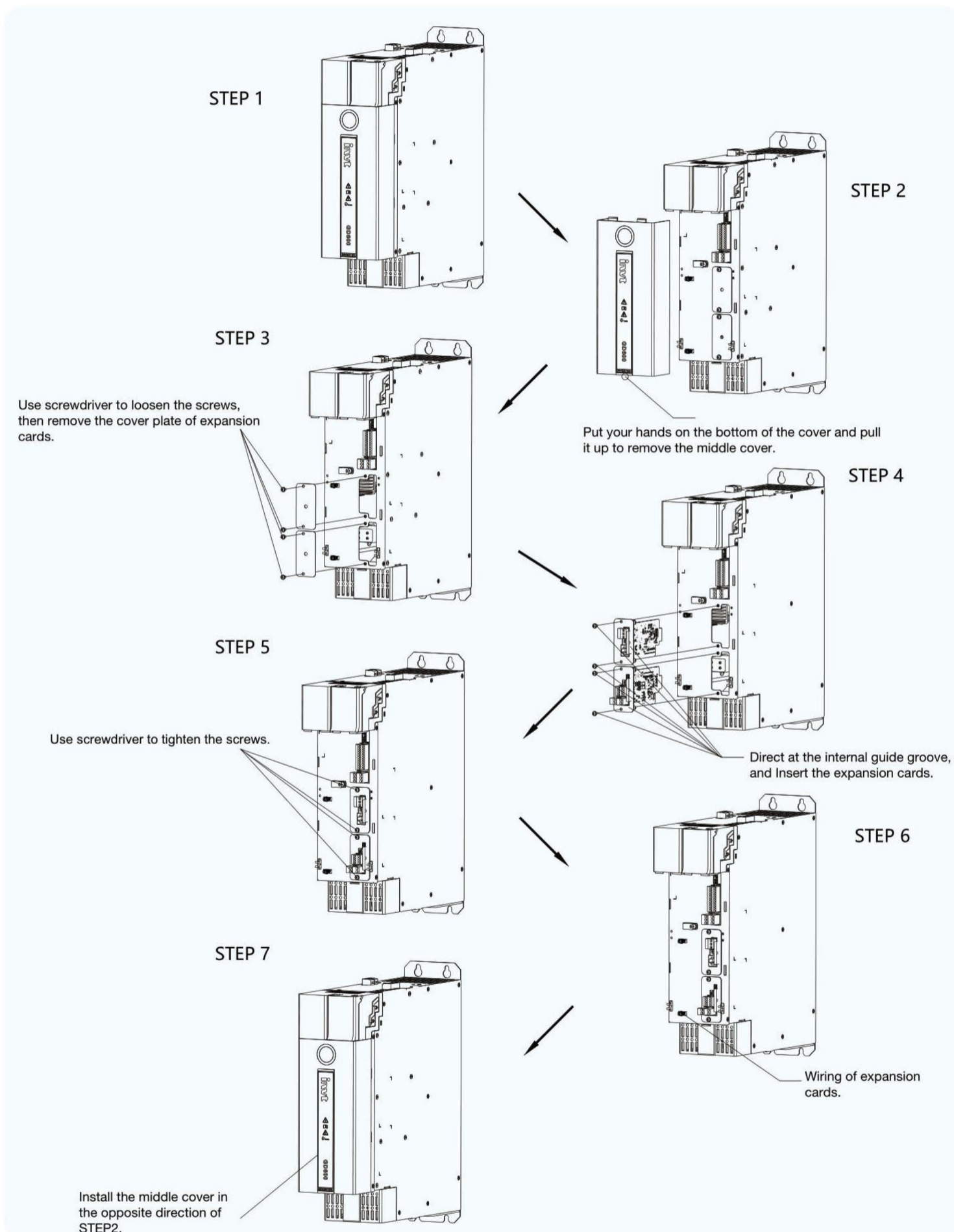

Note:

1. Please install the expansion cards when the power is turned off.
2. Expansion cards can be inserted in any card slot of SLOT1 and SLOT2.
3. If the external wiring interference occurs after the installation of the expansion card, please adjust the installation slot of each expansion card flexibly to the most convenient wiring state. For example, the DP aine connector is large, so it is recommended to install the SLOT2 card slot.

Installation instruction——external terminal of bus

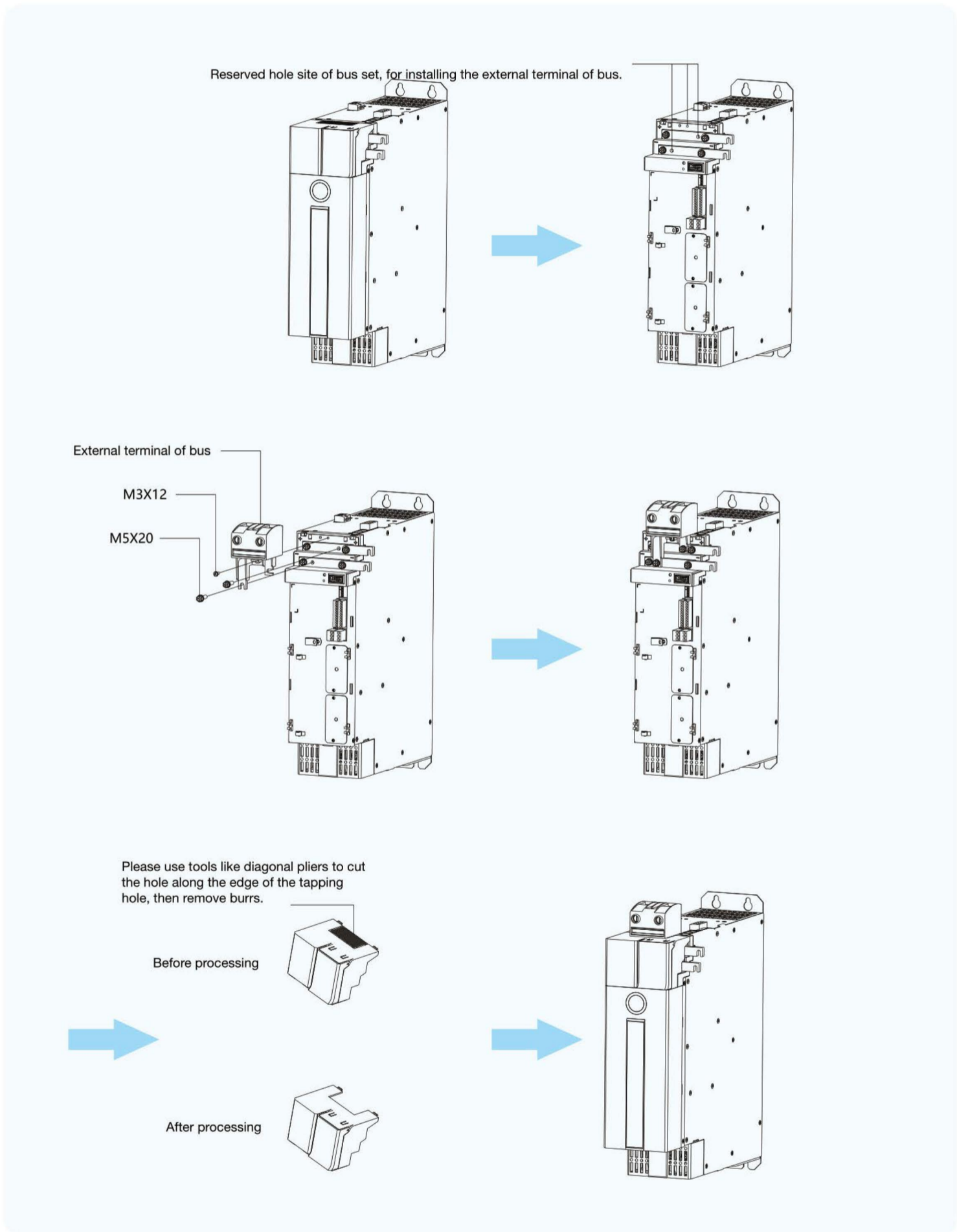

Note: Please refer to the torque below to tighten the crew : M3: 5~6 kgf.cm;M5: 25~28 kgf.cm.

Sales network



★ INVT Headquarters

INVT Office & Service in 11 countries

Sales and Service Partners in 68 countries



Your Trusted Industry Automation Solution Provider



SHENZHEN INVT ELECTRIC CO., LTD.

INVT Guangming Technology Building, Songbai Road, Matian, Guangming District, Shenzhen, China

Industrial Automation:

- Variable-Frequency Drive
- Servo & Motion Control
- Motor & Electric Spindle
- PLC
- HMI
- Intelligent Elevator Control System
- Traction Drive

Electric Power:

- SVG
- Solar Pump Controller
- UPS
- Online Energy Management System
- New Energy Vehicle Electric Control System